



US VACUUM PUMPS LLC

CP-15B

ROTARY VANE SINGLE STAGE VACUUM PUMP



US VACUUM pump Model CPS-15B is a Single stage, Air-cooled, Rotary vane vacuum pump capable of producing an ultimate vacuum to 2 mm Hg (29.8" Hg).

The pump is small and compact yet produces a very generous 15 cfm of inlet pumping capacity. Typical applications include vacuum drying, impregnation, food packaging, vacuum chucking and de-gassing.

Standard accessories include 110V power cord, rubber mounting Feet and inlet hose barb.

TECHNICAL DATA

PUMP TYPE	CPS-15B	
Pump Displacement	CFM	15
Ultimate Vacuum	Torr	2
Pump Speed	RPM	3500
Oil Capacity	ml	500
Inlet connection	Inch	1/2
Motor-Installed power	HP	1.25
Weight	LBS	42
Noise level	db(A)	72

Vacuum Tank system

- Vacuum pump
- 15 gallon tank
- Inlet Filter
- Motor Starter (110V or 220V)
- Vacuum Gauge
- Rubber mounts

\$1,850.00

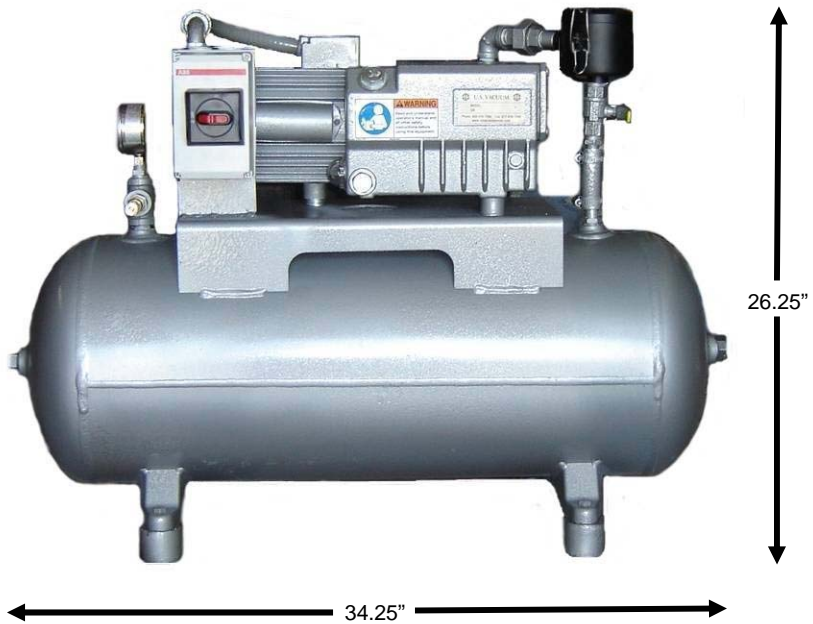

DIMENSIONS

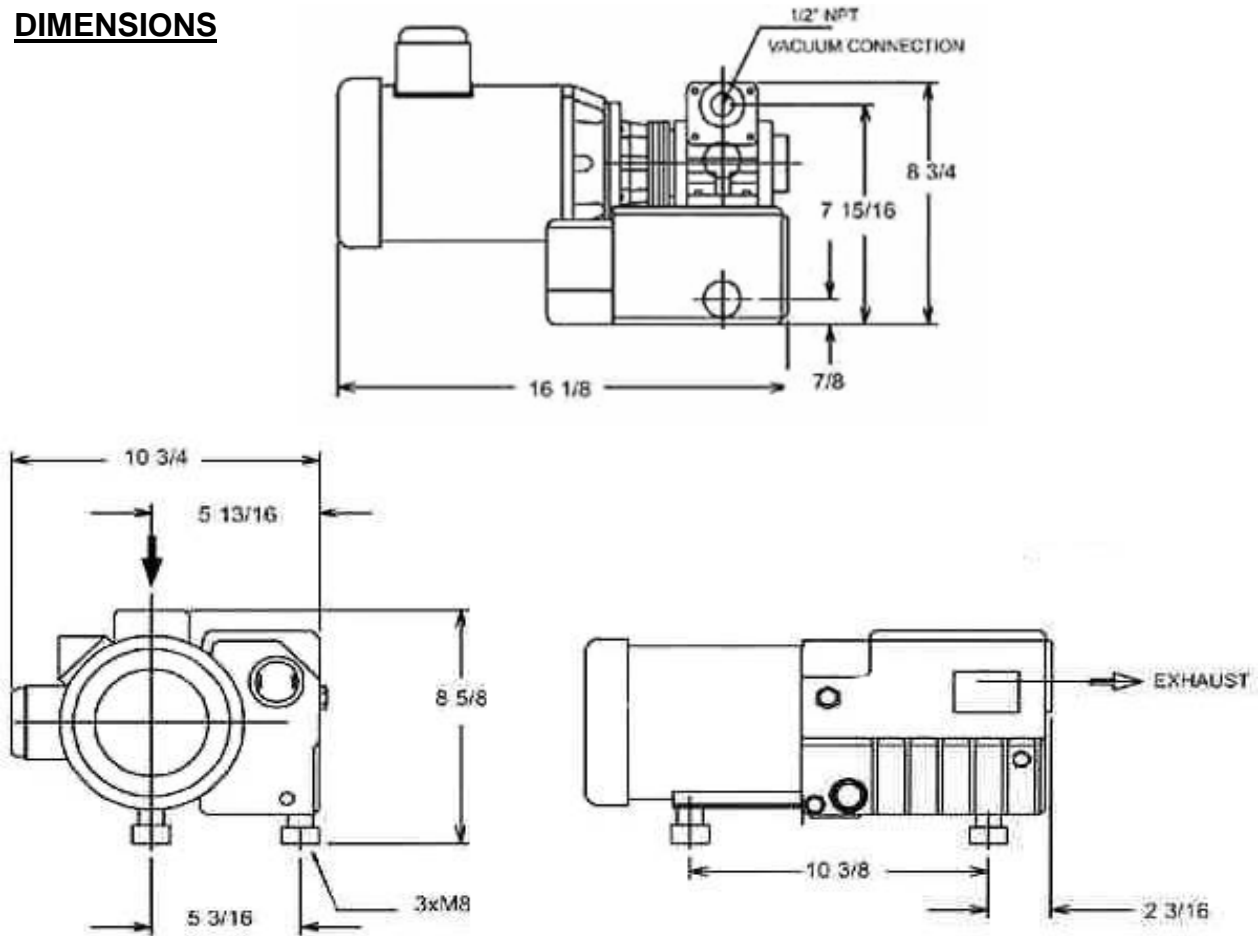

PERFORMANCE CURVE

