

KINNEY® KT™ – Low Profile (LP)

Low Profile, Oil-Sealed Rotary Piston Vacuum Pump

Models:

KT-170LP KT-275LP KT-505LP KT-840VFP KT-1350VFP

Features:

- Full pumping speed down to 1 Torr; Ultimate pressure to 10 microns
- Low profile design (LP Designations)
- Unequaled durability even in dirty applications
- Integral Oil Mist Eliminator
- No metal-to-metal contact in pumping chamber
- Triplex piston design provides quiet, vibration-free operation
- Adjustable gas ballast permits handling of condensable vapors
- Compact design with easy access for maintenance
- Simple installation – no anchor bolts required



Specifications:

	MODEL	KT-170LP	KT-275LP	KT-505LP	KT-840VFP*	KT-1350VFP*
Displacement at Rated RPM	CFM / m ³ /h	94 / 160	162 / 275	297 / 505	484 / 820	778 / 1325
Motor	HP / kW	5 / 3.7	10 / 7.5	15 / 11	30 / 22	40 / 30
Pump RPM	RPM	1150	1200	875	744	581
Cooling Water (min.) @ 80°F (27°C)	GPM / L/min	1 / 4	1 / 4	1.5 / 6	2.5 / 9	3.5 / 13
Oil Capacity	Gal / Liters	2.6 / 10	4.5 / 17	10 / 38	15 / 57	28 / 106
Operating Weight	Lbs. / kg	750 / 340	900 / 408	1870 / 848	3650 / 1660	4375 / 1989
Maximum Gas Ballast (GB) Flow	CFM / m ³ /h	8 / 14	11 / 18	20 / 34	34 / 58	62 / 105
Typical Blank Off Pressure with 5% GB	Torr / mbar	2 / 3	2 / 3	2 / 3	2 / 3	2 / 3
Ultimate Pressure (McLeod Gauge)	Torr / mbar	0.010 / 0.013	0.010 / 0.013	0.010 / 0.013	0.010 / 0.013	0.010 / 0.013
Typical Noise Level @ 10 Torr	dB(A)	71	72	72	73	75

* VFP is Vertical Foot Print Design, and does not appear as shown above, see outline on back for details.

Typical Pumping Speed Curves

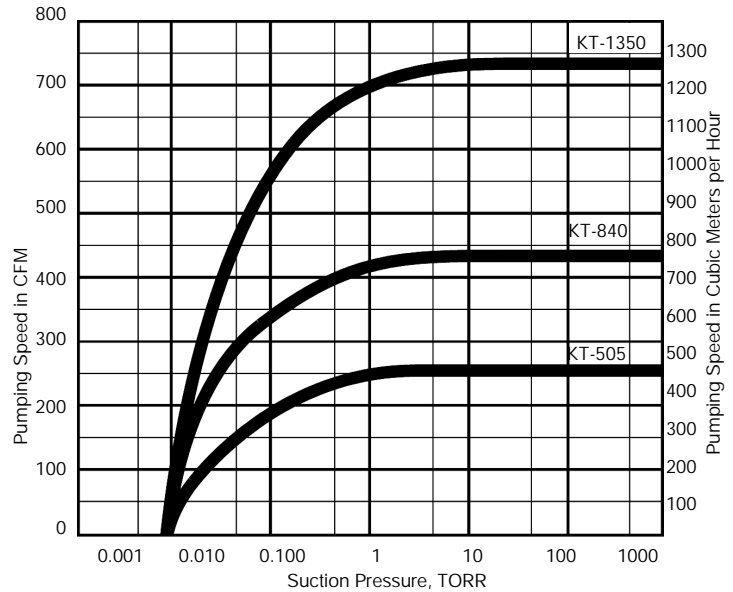
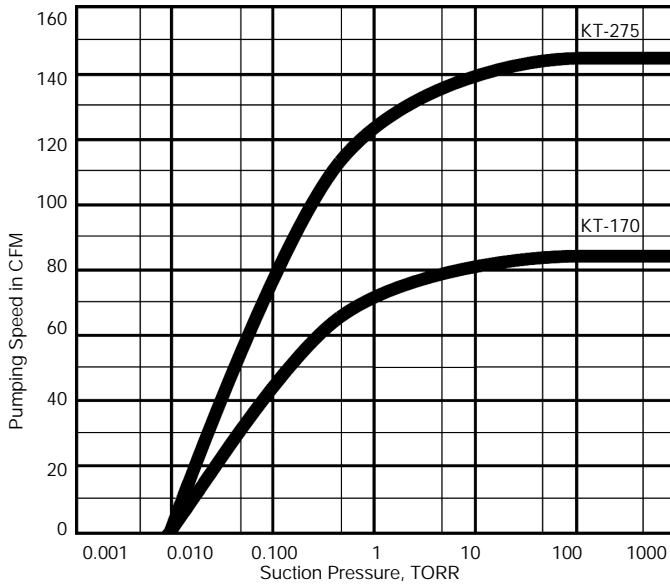

Your Local Tuthill Vacuum & Blower Systems Sales Professional:



TUTHILL
Vacuum & Blower Systems



DISTRIBUTED BY:

U.S. Vacuum Pumps, Inc

CHICAGO: 888-416-7366

DALLAS: 888-416-7466

<http://usvacuumpumps.com>

Dimensions

Values shown are approximate and should not be used for construction.
 Certified drawings are available through your local Tuthill Vacuum & Blower Systems Sales Professional.

Model KT-170LP

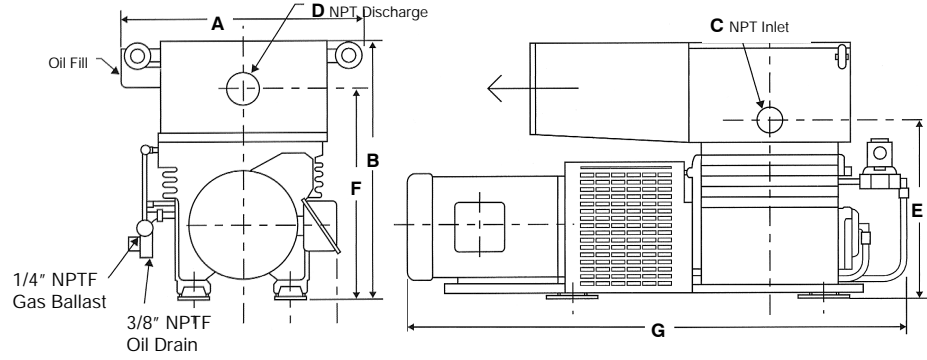

Models KT-275LP, KT-505LP

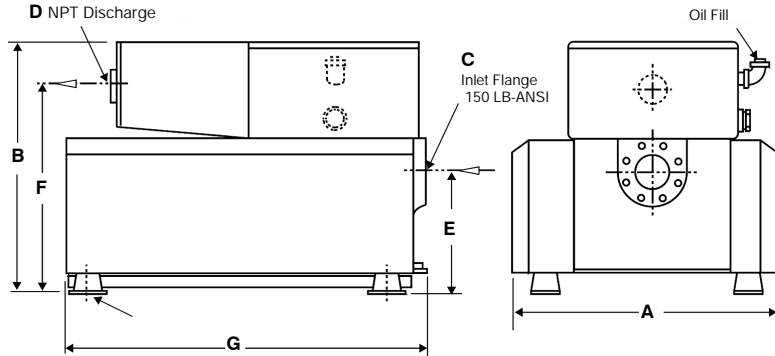

Models KT-840VFP, KT-1350VFP

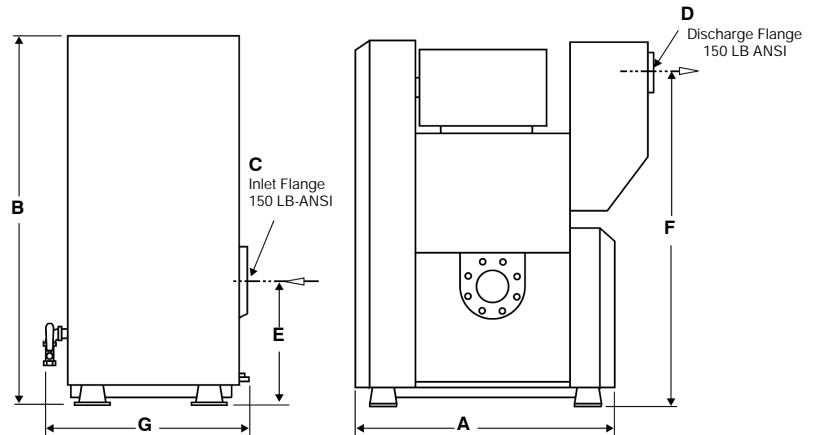

Model (in. / mm)	A	B	C Inlet	D Discharge	E	F	G
KT-170LP	26 660	24.5 622	3" NPT	2" NPT	13 330	21 533	36.5 927
KT-275LP	28 711	25.5 648	3" ANSI	2" NPT	13.75 349	21.75 552	40.5 1029
KT-505LP	35.25 895	33.25 845	4" ANSI	3" NPT	16.25 413	27.5 699	48 1219
KT-840VFP	41 1041	67 1702	6" ANSI	4" ANSI	21 533	61.25 1556	33 838
KT-1350VFP	50.5 1283	76 1930	8" ANSI	5" ANSI	25 635	69 1753	37.5 953

ADVANCING THE STANDARDS IN VACUUM TECHNOLOGY

Your Local Tuthill Vacuum & Blower Systems Sales Professional:



TUTHILL
 Vacuum & Blower Systems



DISTRIBUTED BY:
 U.S. Vacuum Pumps, Inc
 CHICAGO: 888-416-7366 DALLAS: 888-416-7466
<http://usvacuumpumps.com>