



US VACUUM PUMPS LLC

LRV-20/35/55 Close Coupled Vacuum Pumps



US VACUUM LRV pumps are single stage close-coupled liquid ring vacuum pumps capable of producing a vacuum to 29" Hg . The pumps are available in various materials of construction (FS = Cast iron casing/ Stainless steel impeller, SS = All stainless steel).

Pumps are provided with threaded connections for service liquid, pump draining and vacuum relief valve. Optional items include inlet check valve, vacuum relief valve, flow control, solenoid valve, vacuum and temperature gauges.

TECHNICAL DATA

PUMP TYPE		LRV 20C	LRV 35C	LRV 55C
Pumping Capacity (@ 25" Hg)	CFM	18	32	46
Speed	RPM	3500	3500	3500
Motor-Installed power	HP	1.5	3	5
Average service liquid flow	GPM	1	1.5	2.5
Noise level at 60 Torr	db(A)	69	70	71
Minimum suction pressure	Torr	25	25	25
Weight	Lbs	40	57	91

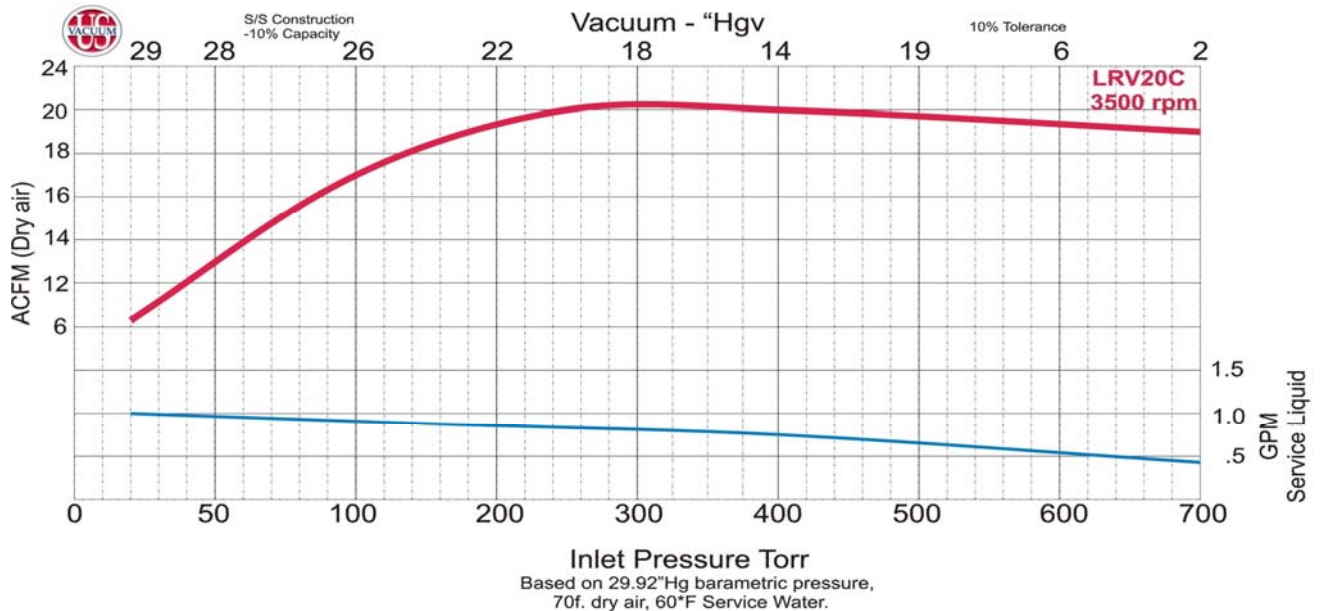

PERFORMANCE CURVES

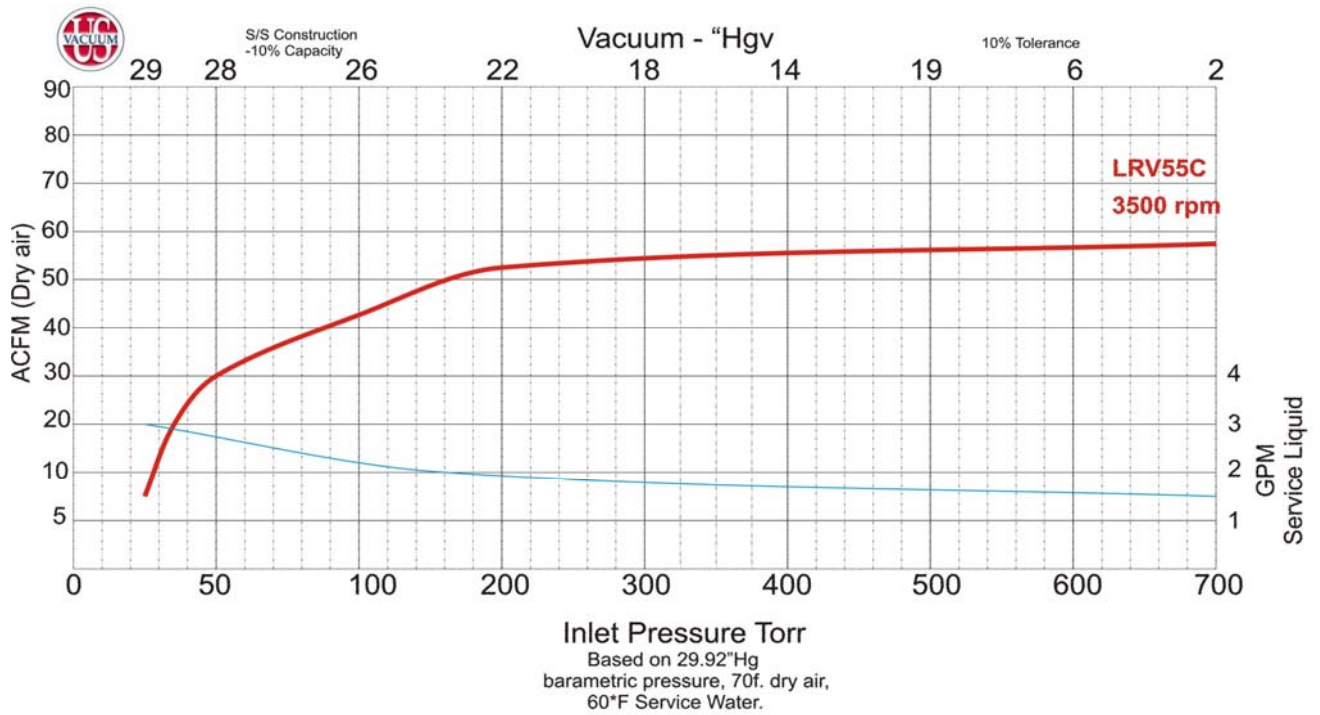
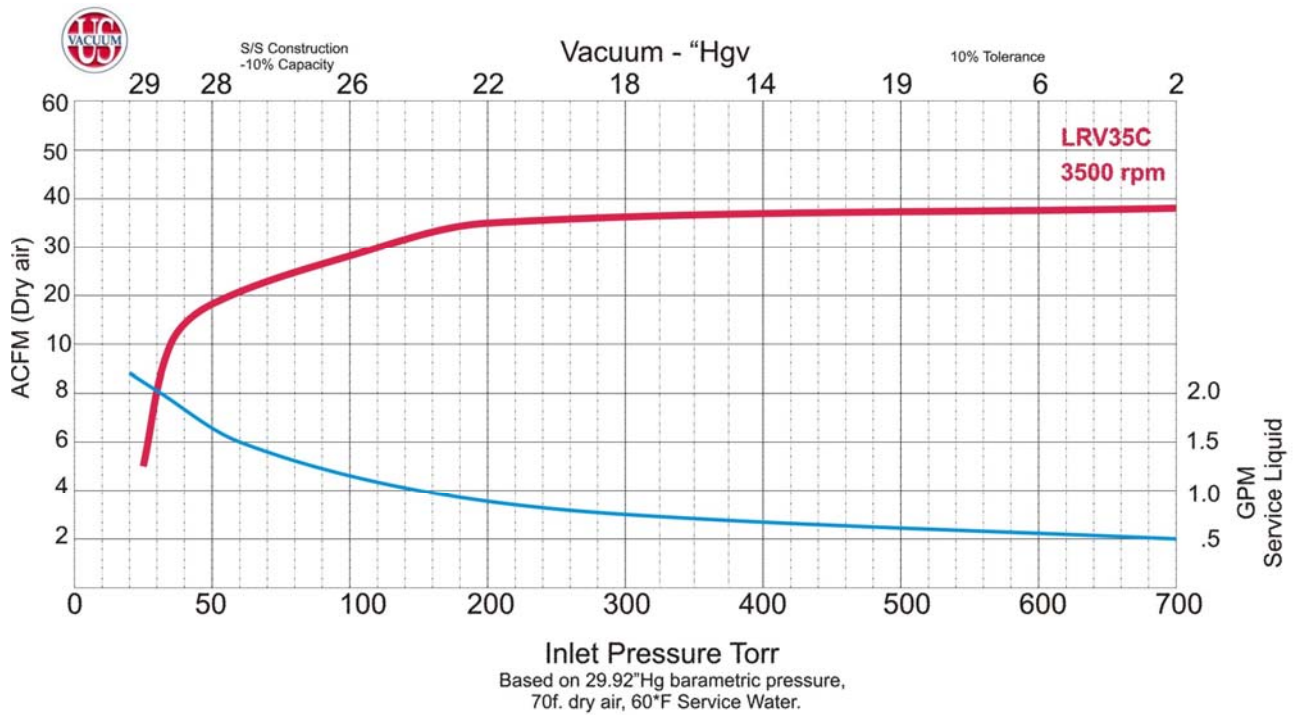

LRV-20C

d5 = Anti-cavitation port 1/8"
 d6 = Seal liquid inlet 1/4"
 d7 = Drain port 1/4"

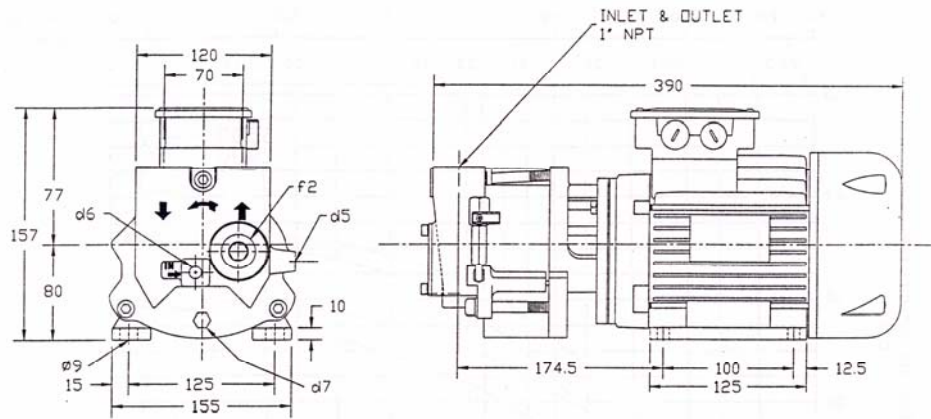

LRV-35C

d5 = Anti-cavitation port 1/8"
 d6 = Seal liquid inlet 1/4"
 d7 = Drain port 1/8"

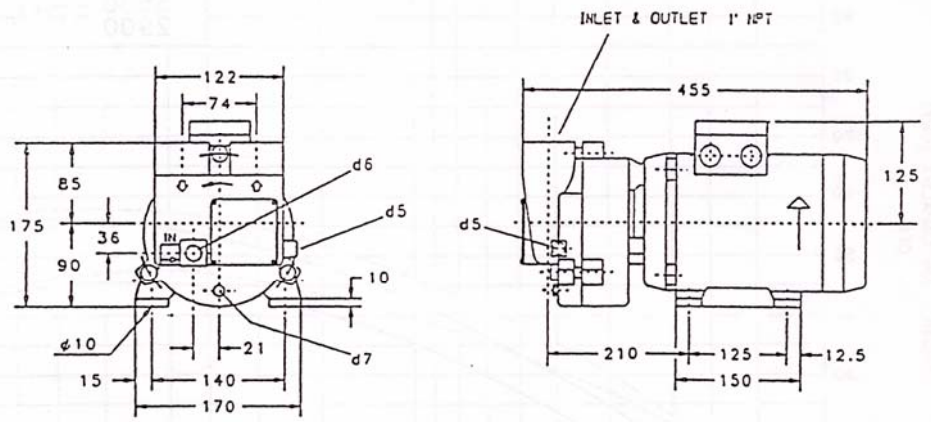

LRV-55C

d5 = Anti-cavitation port 1/8"
 d6 = Seal liquid inlet 3/8"
 d7 = Drain port 1/8"

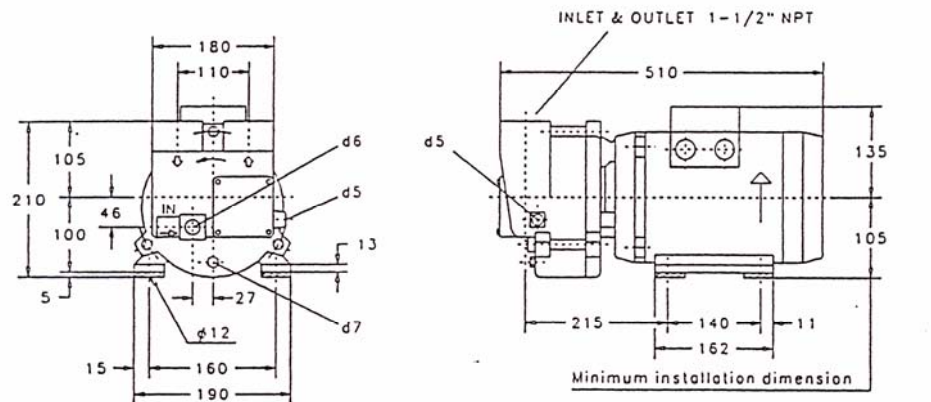

All dimensions in mm
 25.4 mm = 1"