



US VACUUM PUMPS LLC

TV-160B/250B Rotary Vane Vacuum Pumps



US VACUUM TorrVac vacuum pumps are Single stage Air-cooled Rotary Vane Direct drive vacuum pumps capable of producing an ultimate vacuum of 29.9" Hg (0.5 mm Hg) . The pumps are rugged and designed for continuous operation in industrial applications.

These pumps are compact, quiet and meet the needs of both the industrial and O.E.M. user. Features include integral oil mist filter providing a 99.9% oil free discharge, non-return valve to isolate the pump in the event of power failure and air cooled design for installation in any location where power is available.

TECHNICAL DATA

PUMP TYPE		TV-160B	TV-250B
Pump Capacity	CFM	112	176
Rotational Speed	RPM	1725	1725
Ultimate Vacuum	Torr	0.5	0.5
Motor	HP	7-1/2	10
Oil capacity	Qts	7	7
Noise level	db(A)	72	74
Inlet/outlet connections	inches	2'	2"
Weight	Lbs	416	460

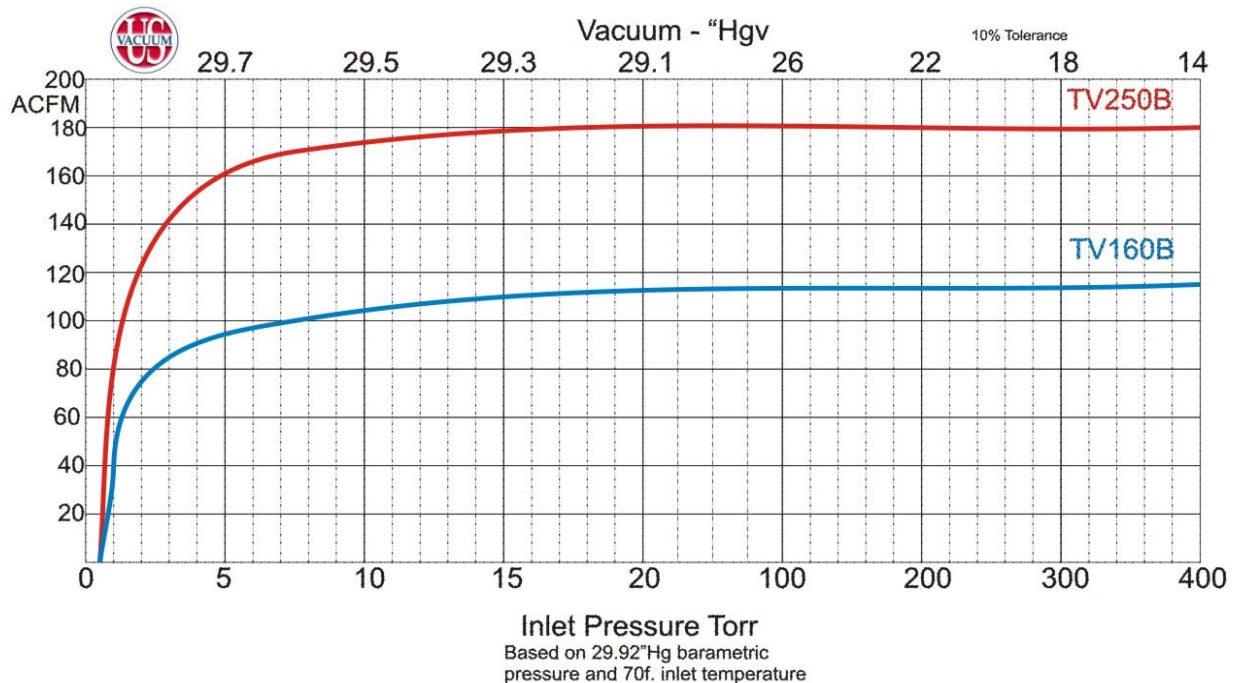

TV-160B/250B

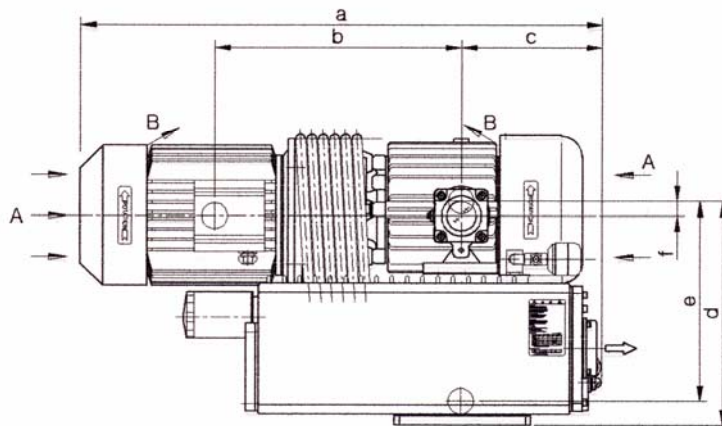
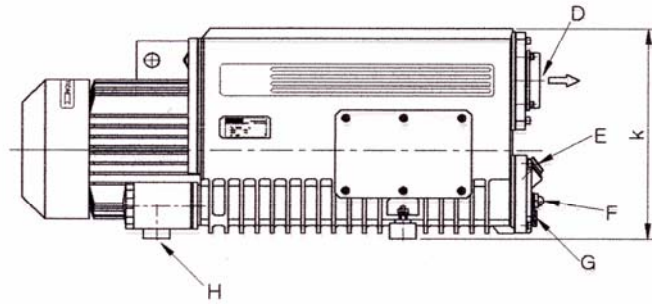
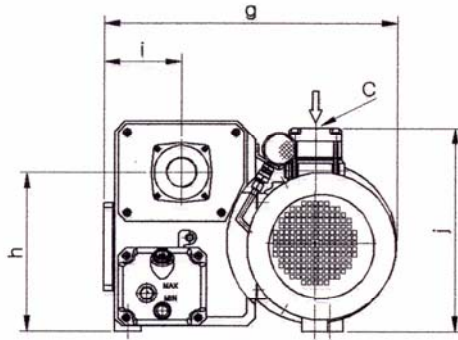

NOTE: Dimensions in mm
(1" = 25.4 mm)

DIMENSIONS (MM)	A	B	C	D	E	F	G	H	I	J	K
TV-160B	945	407	276	440	393	29	570	313	151	400	414
TV-250B	1020	482	276	440	393	29	570	313	151	400	414