



US VACUUM PUMPS

TV-25B & TV-40B Rotary Vane Vacuum Pumps



U.S. VACUUM TV vacuum pumps are Single stage Air-cooled Rotary Vane Direct drive vacuum pumps capable of producing an ultimate vacuum of 29.9" Hg (0.5 mm Hg) . The pumps are rugged and designed for continuous operation in industrial applications.

These pumps are compact, quiet and meet the needs of both the industrial and O.E.M. user. Features include integral oil mist filter providing a 99.9% oil free discharge, non-return valve to isolate the pump in the event of power failure and air cooled design for installation in any location where power is available.

TECHNICAL DATA

PUMP TYPE		TV-25B	TV-40B
Pump Capacity (Displacement)	CFM	21	28
Rotational Speed	RPM	1725	1725
Ultimate Vacuum	Torr	0.5	0.5
Motor	Hp	1.5	2
Oil capacity	Qts	1	3
Noise level	db(A)	64	67
Inlet/outlet connections	inches	1.25	1.25
Weight	Lbs	62	100

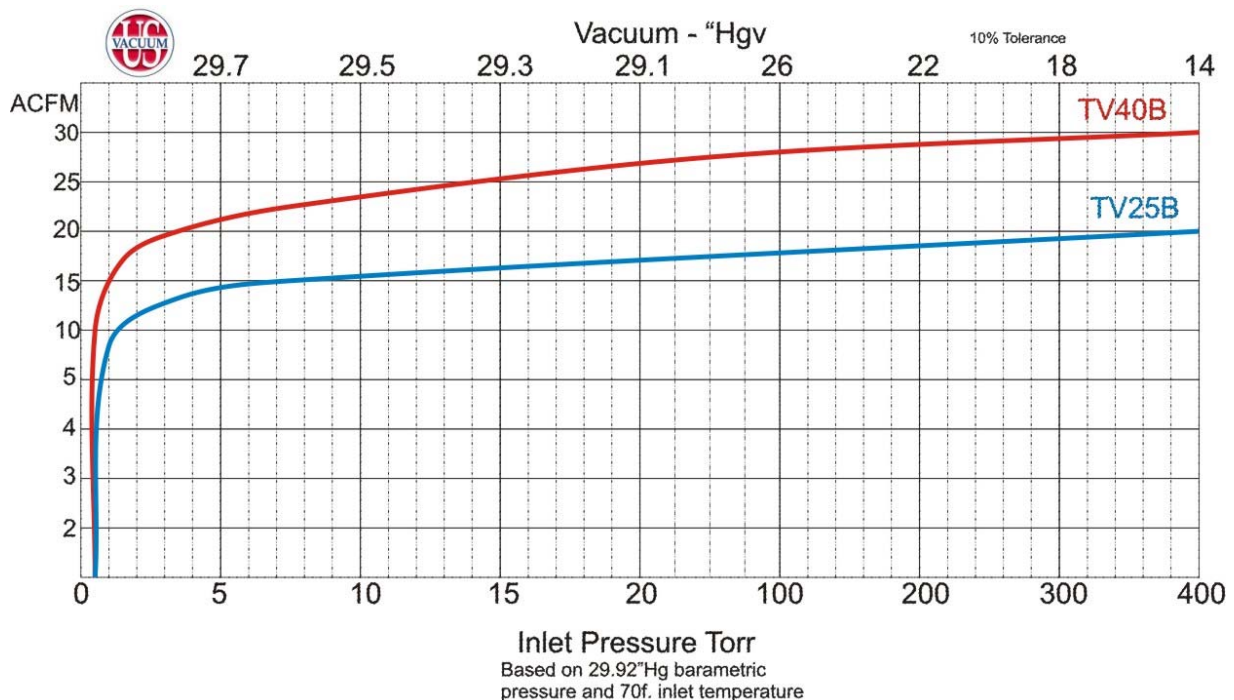

TV-25B/40B

- A Cooling air entry
- B Cooling air exhaust
- C Inlet
- D Exhaust
- E Oil Fill
- F Oil sight glass
- G Oil drain plug

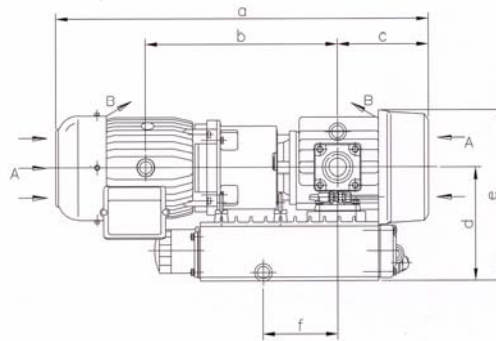
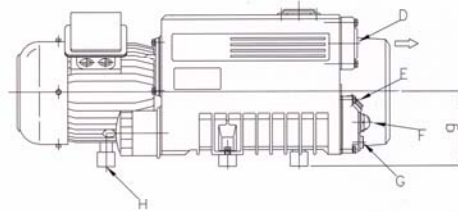
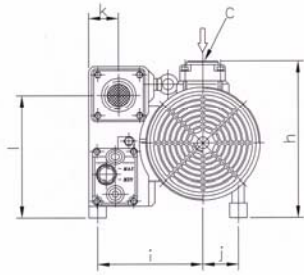

DIMENSIONS (MM)	A	B	C	D	E	F	G	H	I	J	K
TV-25B	605	312	140	195	280	127	122	280	180	60	50
TV-40B	635	327	155	195	280	127	122	280	180	60	50

All dimensions in mm
25.4 mm = 1"