



US VACUUM PUMPS

TV-63B & TV-100B Rotary Vane Vacuum Pumps



U.S. VACUUM TV vacuum pumps are Single stage Air-cooled Rotary Vane Direct drive vacuum pumps capable of producing an ultimate vacuum of 29.9" Hg (0.5 mm Hg) . The pumps are rugged and designed for continuous operation in industrial applications.

These pumps are compact, quiet and meet the needs of both the industrial and O.E.M. user. Features include integral oil mist filter providing a 99.9% oil free discharge, non-return valve to isolate the pump in the event of power failure and air cooled design for installation in any location where power is available.

TECHNICAL DATA

| PUMP TYPE | | TV-63B | TV-100B |
|------------------------------|--------|--------|---------|
| Pump Capacity (Displacement) | CFM | 45 | 70 |
| Rotational Speed | RPM | 1725 | 1725 |
| Ultimate Vacuum | Torr | 0.5 | 0.5 |
| Motor | Hp | 3 | 5 |
| Oil capacity | Qts | 3 | 5 |
| Noise level | db(A) | 68 | 70 |
| Inlet/outlet connections | inches | 1.25 | 1.25 |
| Weight | Lbs | 134 | 190 |

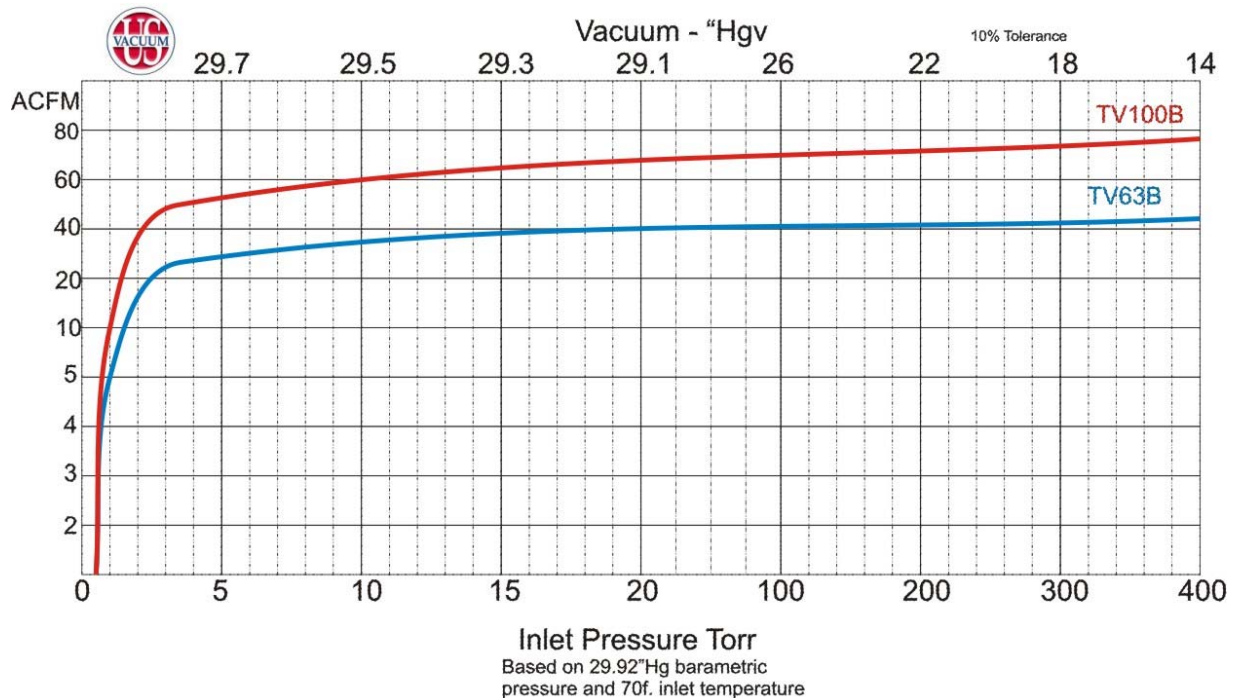

TV-63B/100B

- A Cooling air entry
- B Cooling air exhaust
- C Inlet
- D Exhaust
- E Oil Fill
- F Oil sight glass
- G Oil drain plug

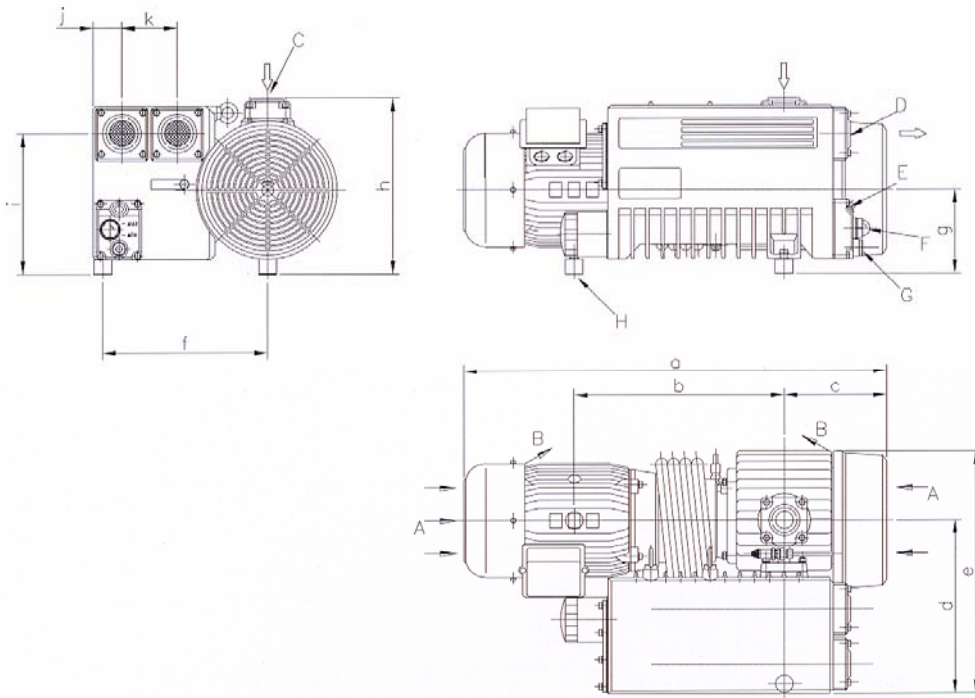

| DIMENSIONS (MM) | A | B | C | D | E | F | G | H | I | J | K |
|-----------------|-----|-----|-----|-----|-----|-----|-----|-----|-----|----|----|
| TV-63B | 663 | 329 | 148 | 292 | 410 | 277 | 145 | 298 | 238 | 49 | 93 |
| TV-100B | 713 | 354 | 173 | 292 | 410 | 277 | 145 | 298 | 238 | 49 | 93 |

All dimensions in mm
25.4 mm = 1"