

DRP SERIES

Dry Piston Vacuum Pumps

DRPC-3 & DRPS-5



DRP Series Dry Piston Vacuum Pumps

The DRP series are **CORROSION RESISTANT** 100% oil-less rocking piston vacuum pumps. They are designed to operate on a continuous basis at any point from atmospheric pressure to the pumps' ultimate vacuum level (10-60 torr depending on the pump model). These pumps are ideal for applications where oil or water sealed pumps are objectionable.

The pumps are supplied standard with a PTFE (Teflon®) coating for corrosion resistance. The units are supplied with electric motor (w/ thermal protector), vacuum gauge, hose connector, exhaust silencer/muffler, support legs and a heavy duty, 8 foot long 120v (15A) power cord with N. American plug and on-off switch.

Applications include medical, dental, chip mounting/holding, air sampling, vacuum packaging, material handling, environmental equipment and others.

FEATURES

- Oil-less operation
- Low noise & Light weight
- Corrosion Resistant (PTFE)
- Stainless steel valves
- Virtually maintenance-free
- Vacuum to 29.5"Hg (DRPC Model)



SPECIFICATIONS

Pump Model		DRPC-2.5	DRPS-5
Displacement	CFM	2.5	5
Ultimate Vacuum	Torr	10 (29.5"Hg)	60 (27.5"Hg)
Motor	Hp	1/3	1/3
Motor type		Capacitor Start w/ thermal protection & cooling fan; 120 v, 60hz	
Noise Level	dBa	53	58
Inlet connection	in.	1/4"	1/4"
Dimensions	mm	9.45" (L) x 4.64 (W) x 6.5 (H)	
Pump Weight	Lbs.	16	16

DIMENSIONS

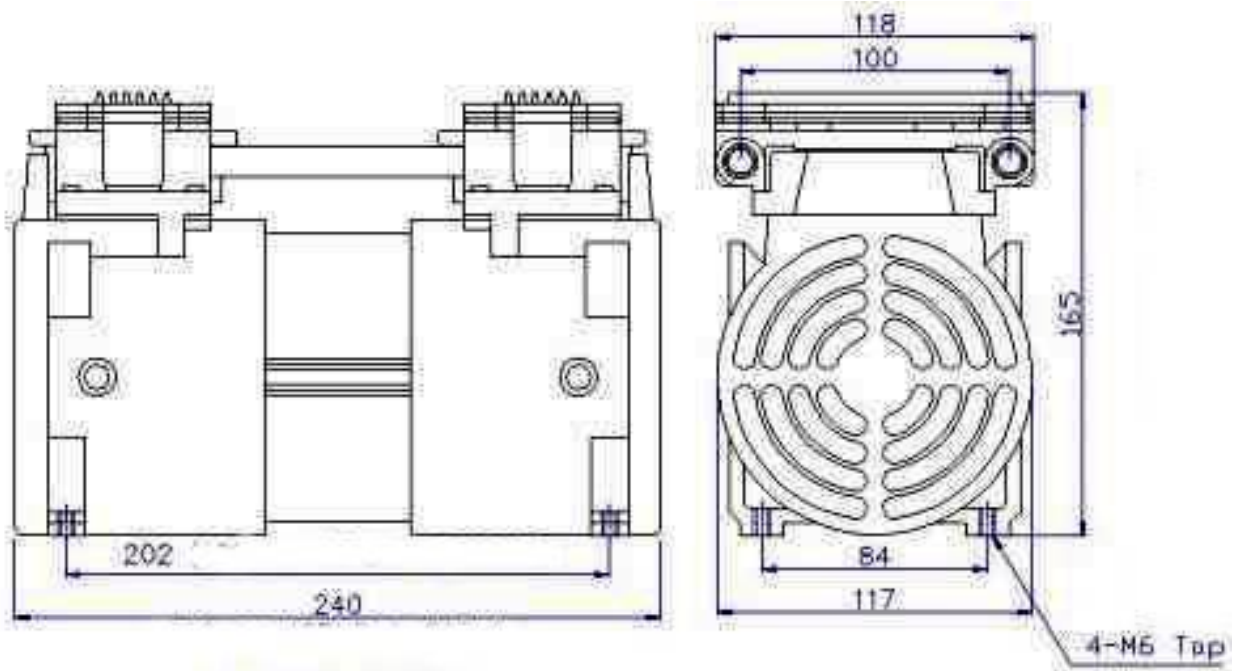

Dimensions in mm

US VACUUM

US Vacuum Pumps LLC
P.O. Box 909
Canton, TX 75103
Phone: (888) 416-7366
Fax: (877) 416-7599
WEB: www.usvacuumpumps.com