

DV SERIES

Dry Vane Vacuum Pumps

DV10, DV17, DV25, DV50



DV Series Rotary Vane Dry Vacuum Pumps



Model DV10
Displacement 10 CFM
Ultimate Pressure : 25" Hg

The DV series of pumps are 100% oil-less rotary vane vacuum pumps. They are designed to operate on a continuous basis at any point from atmospheric pressure to a vacuum level of 25" Hg. The oil-less pumps are ideal for applications where oil or water sealed pumps are objectionable.

The pumps come complete with electric motor, power cord (115v, 60hz), inlet filter, mounting feet and discharge muffler. Other motor options available including: 3-phase, 50hz, explosion-proof, etc (Models DV10, 17, 25, 50 only).

Applications include graphic arts, vacuum packaging, forming, hold-down, robotics, material handling, air sampling, central vacuum systems and others.



Model DV25
Displacement 25 CFM
Ultimate Pressure: 25" Hg



Model DV 50
Displacement 48 CFM
Ultimate Pressure : 25" Hg

DV SERIES

MODEL	DV 10	DV 17	DV 25	DV 50
Displacement, CFM	10	17	25	48
Max Cont. Vacuum ("Hg)	25" Hg			
Motor, Hp	1/2	1	2	3
Suction Connection	3/4"	3/4"	3/4"	1"
Speed (RPM)	1750			1200
Weight, Lbs	46	60	80	176
Noise Level dBa	70	70	73	76

PERFORMANCE CURVES

DV-10, DV-17, DV-25

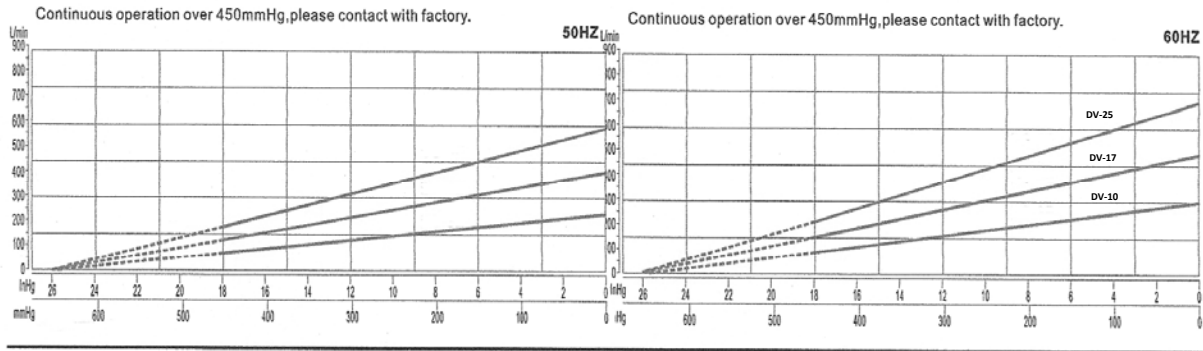

DV-50

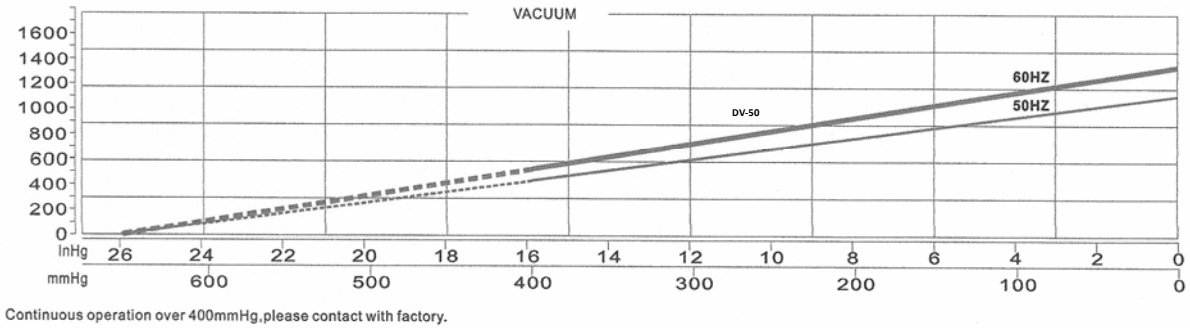

Flow in Liter/Min. ...divide by 28 for CFM (cubic feet/Min)

DV 10 DIMENSIONS

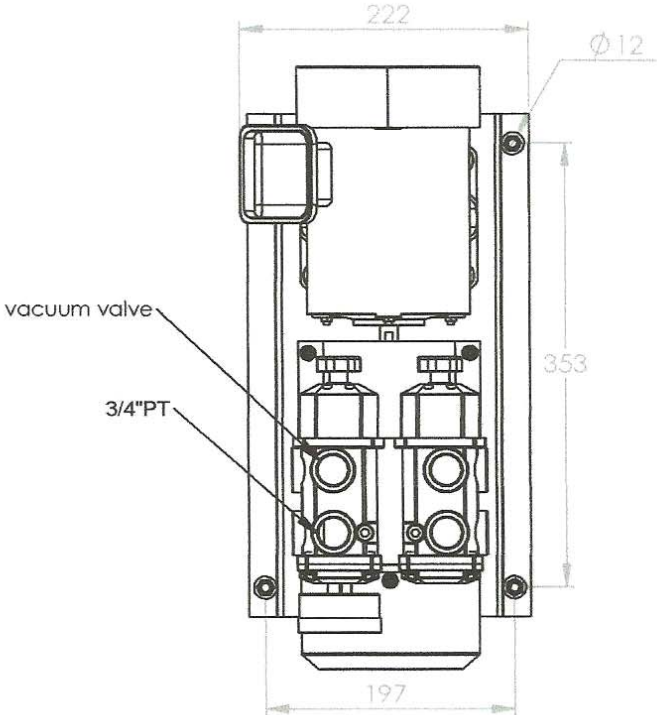
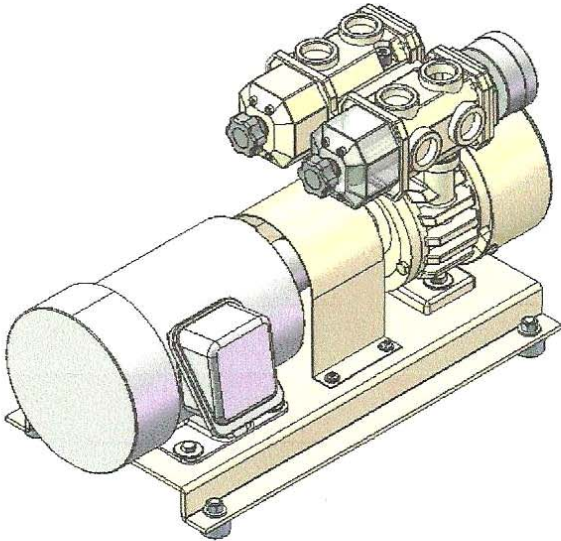
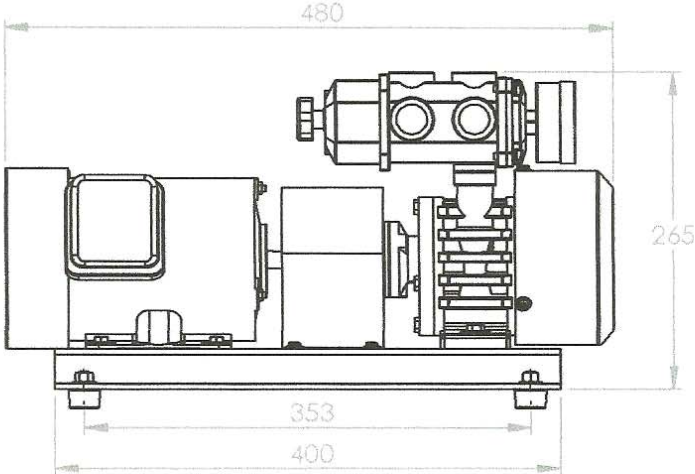
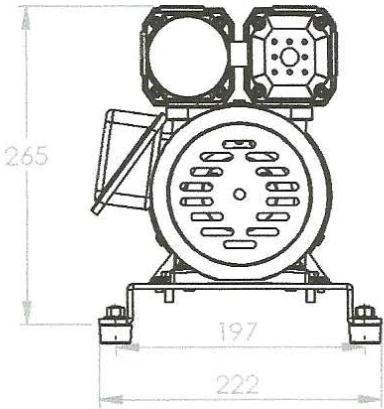

DV 17 DIMENSIONS

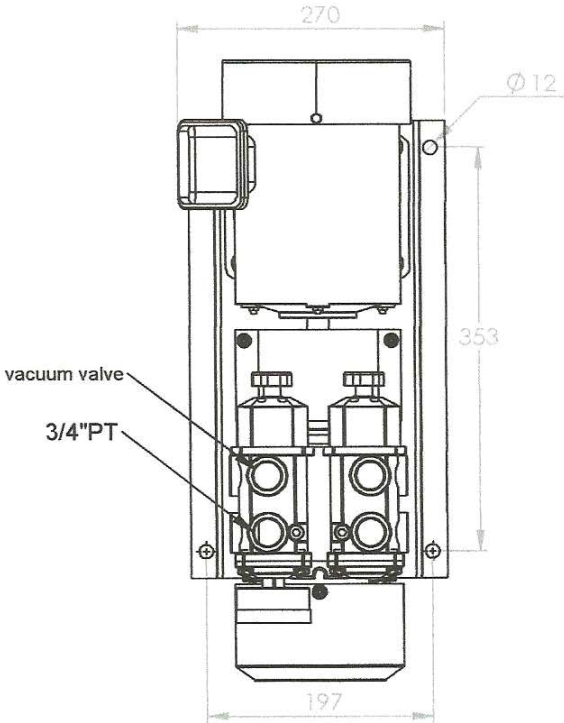
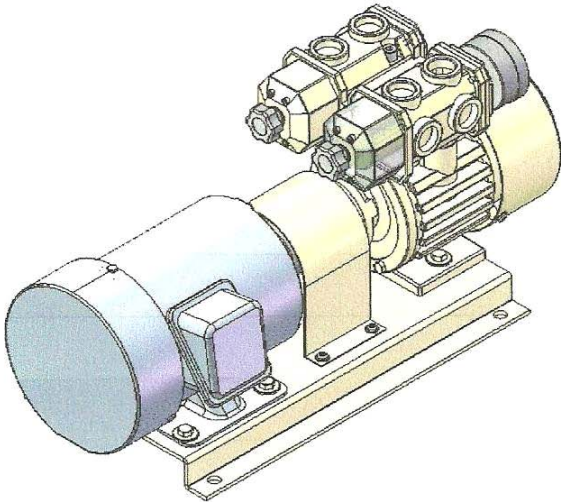
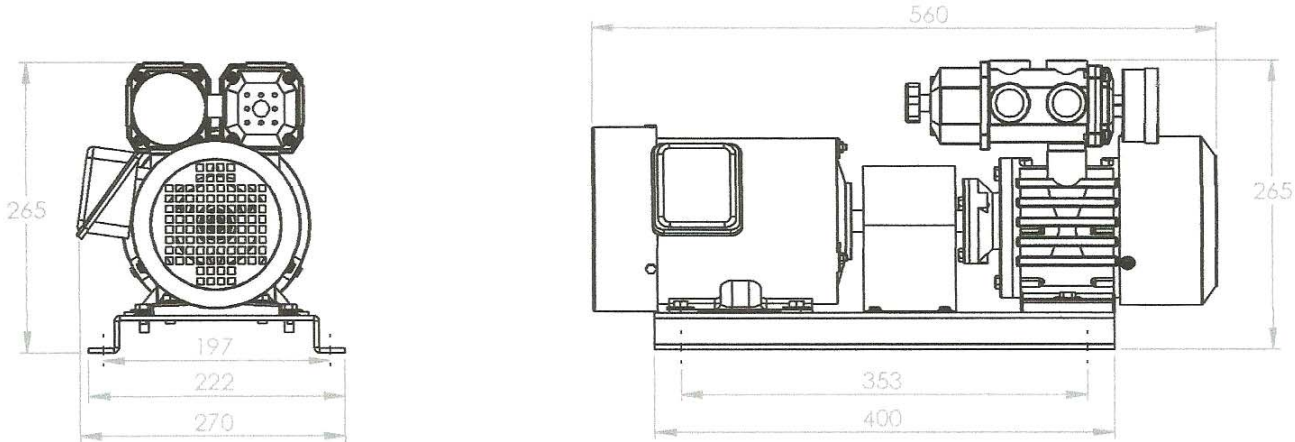

DV 25 DIMENSIONS

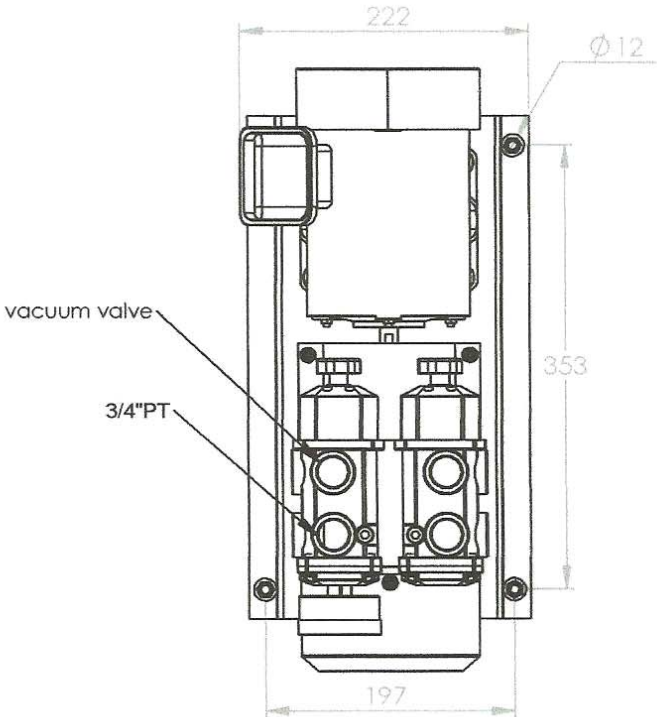
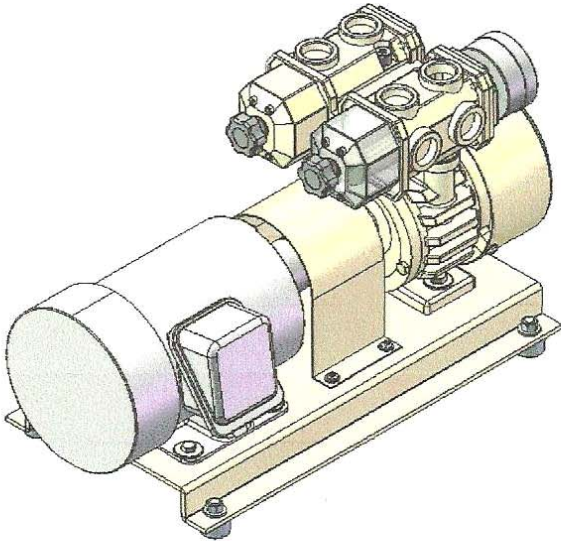
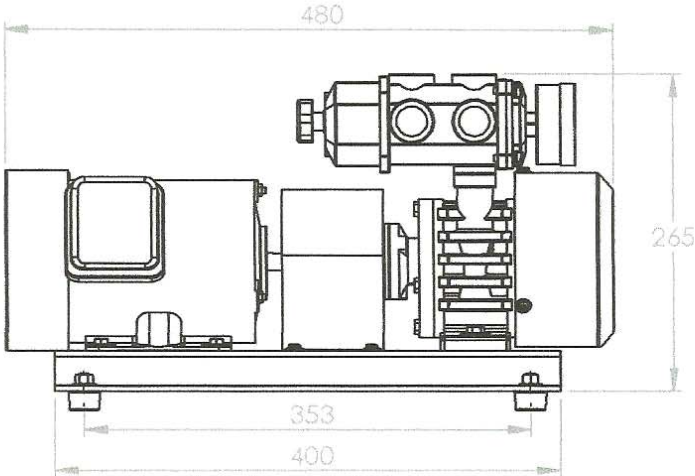
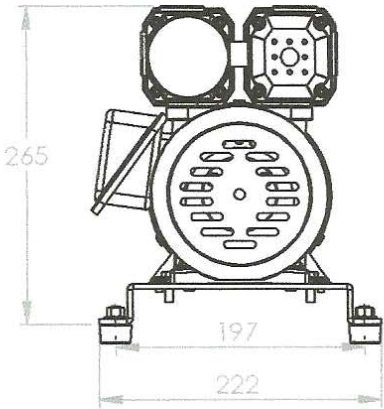

DV 50 DIMENSIONS

