



# U.S. VACUUM PUMPS, LLC

## LRH-400/500/850

BARE SHAFT CONSTRUCTION W/ MECHANICAL SEAL



U.S. VACUUM LRH pumps are Two stage liquid ring vacuum pumps capable of producing a vacuum to 29" Hg . The pumps are available in various materials of construction ( FB = Iron/Bronze, FS = Iron/Stainless steel, SS = All stainless steel ).

Pumps are provided with threaded connections for service liquid, pump draining, vacuum relief valve and companion flanges. Optional items include inlet check valve, vacuum relief valve, flow control, solenoid valve, vacuum and temperature gauges.

Pumps can also come as completely packaged units using water or water as a seal fluid.

### TECHNICAL DATA

PUMP TYPE		LRH 400	LRH 500	LRH 850
Pumping Capacity (@ 25" Hg)	CFM	400	500	840
Speed	RPM	1750	1750	1150
Motor-Installed power	HP	40	50	75
Average service liquid flow	GPM	10	12.5	30
Noise level at 60 Torr	db(A)	79	79	82
Minimum suction pressure	Torr	25	25	25

### LRH-400/500 Dimensions

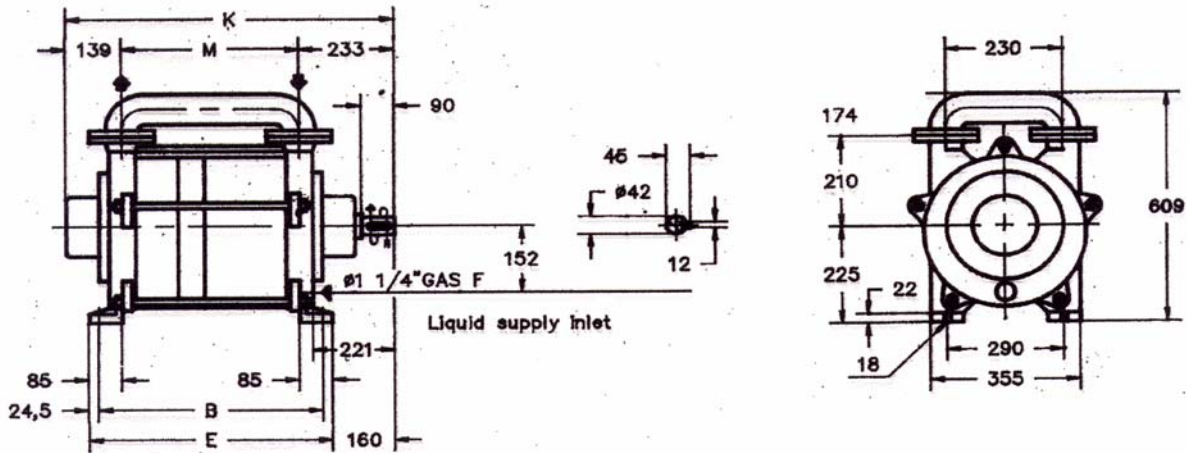

PUMP TYPE	B	E	M	K	Weight Lbs
LRH 400	575	624	475	847	484
LRH 500	660	709	560	932	528

NOTE: Dimensions in mm  
(1" = 25.4 mm)

# LRH-850

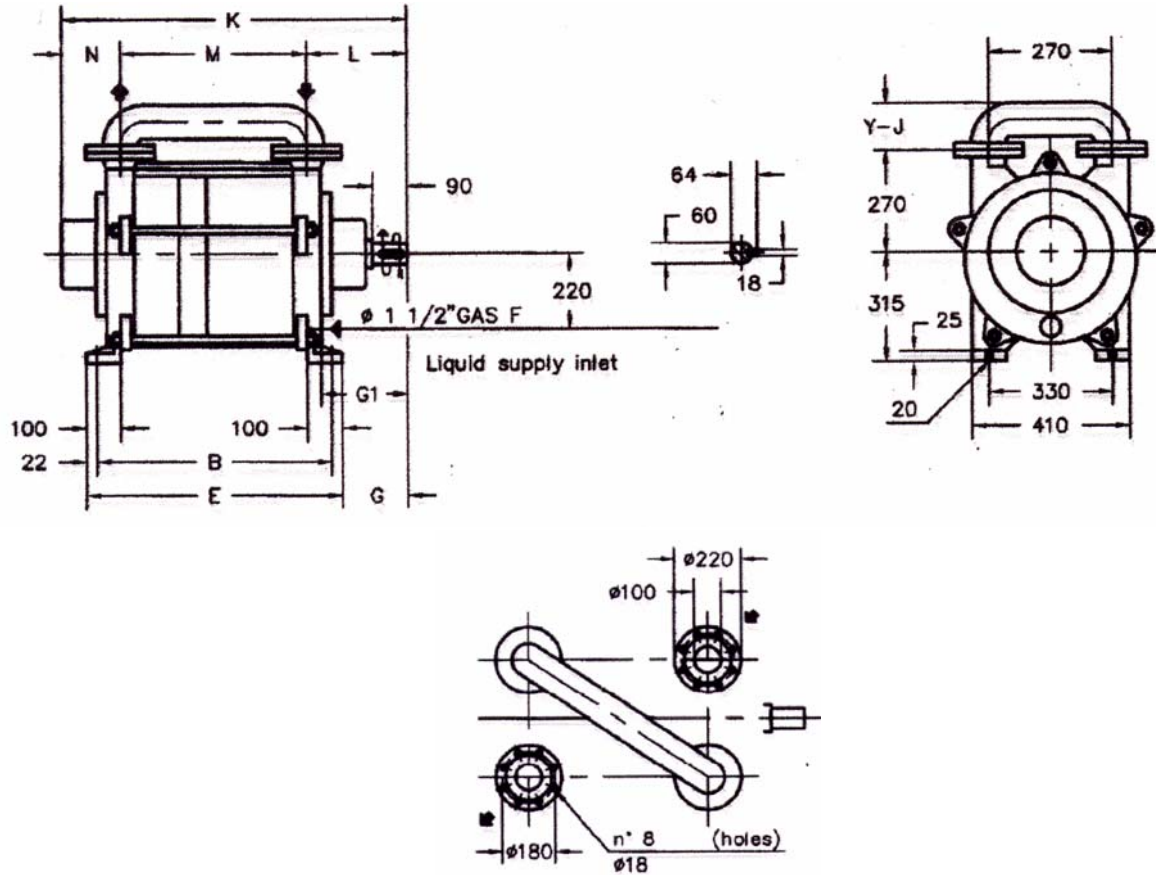

PUMP TYPE	B	E	M	Y	J	G	G1	K	L	N	Weight Lbs
LRH 850	822	866	696	207	225	150	220	1068	235	137	1067

NOTE: Dimensions in mm  
(1" = 25.4 mm)



# U.S. VACUUM

DATA BASED ON :  
 DRY AIR AT 68 °F - 20 °C  
 SATURATED AIR AT 68 °F - 20 °C  
 SERVICE LIQUID WATER  
 SERVICE LIQUID TEMPERATURE 59 °F - 15 °C  
 DISCHARGE PRESSURE 1013 mbar

S.S. PUMPS  
 CAPACITY : -10%

Tol.: 10%

PERFORMANCE DATA  
 LIQUID RING VACUUM PUMP  
 PUMP MODEL

LRH 400

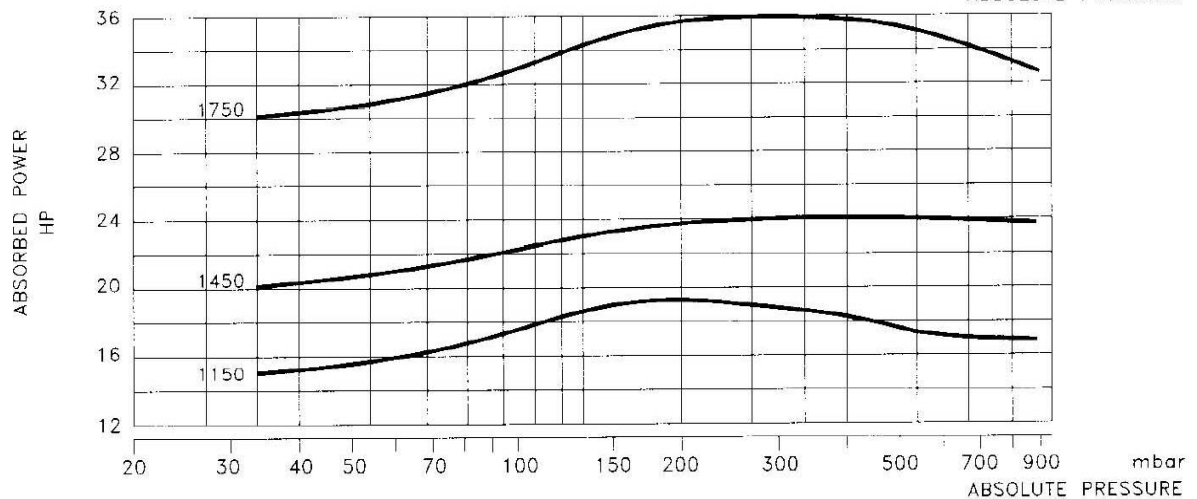
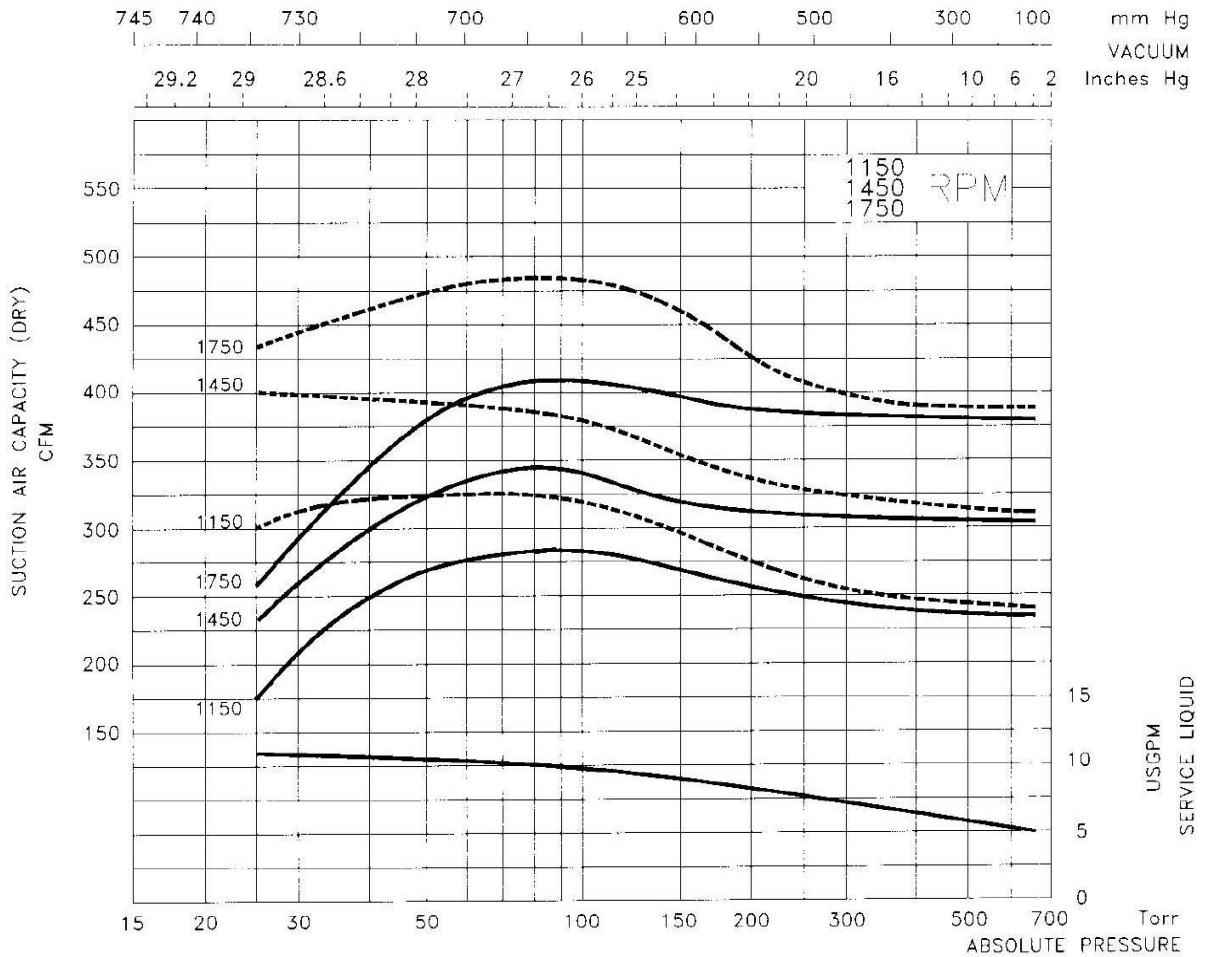



# U.S. VACUUM

DATA BASED ON :  
DRY AIR AT 68 °F - 20 °C  
SATURATED AIR AT 68 °F - 20 °C  
SERVICE LIQUID WATER  
SERVICE LIQUID TEMPERATURE 59 °F - 15 °C  
DISCHARGE PRESSURE 1013 mbar

S.S. PUMPS  
CAPACITY : -10%

Tol.: 10%

PERFORMANCE DATA  
LIQUID RING VACUUM PUMP  
PUMP MODEL  
LRH 500

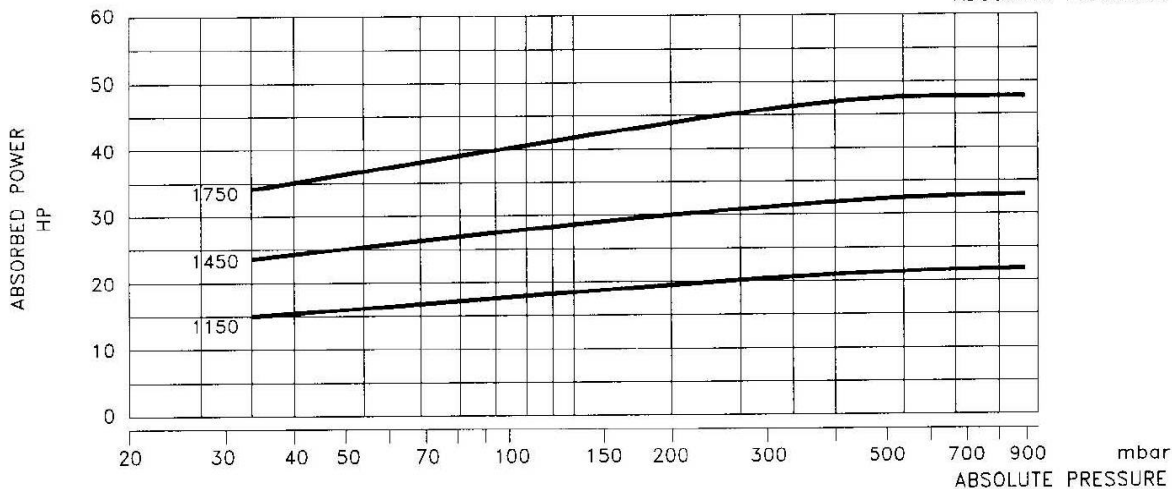
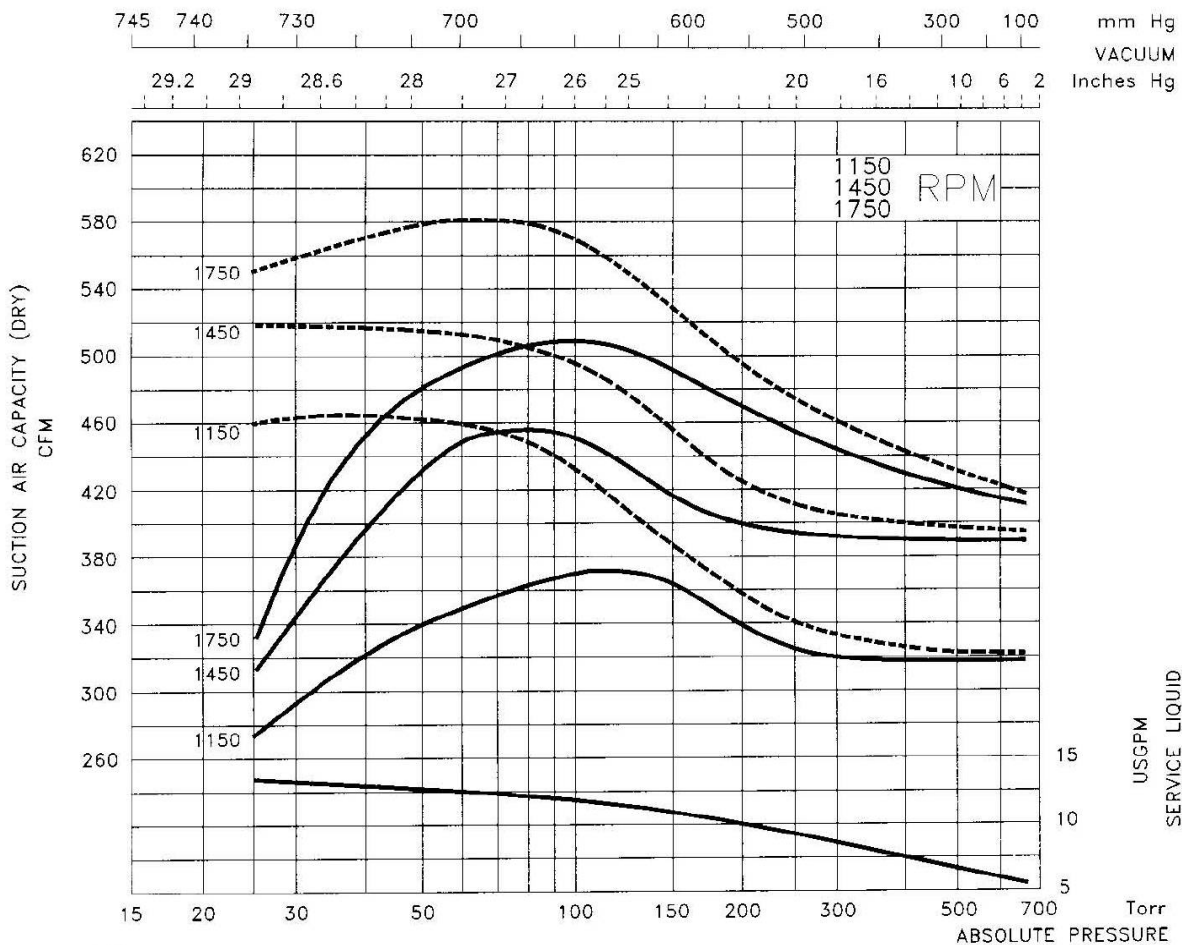



# U.S. VACUUM

DATA BASED ON :  
 DRY AIR AT 68 °F - 20 °C  
 SATURATED AIR AT 68 °F - 20 °C  
 SERVICE LIQUID WATER  
 SERVICE LIQUID TEMPERATURE 59 °F - 15 °C  
 DISCHARGE PRESSURE 1013 mbar

S.S. PUMPS  
 CAPACITY : -10%  
 Tol.: 10%

PERFORMANCE DATA  
 LIQUID RING VACUUM PUMP  
 PUMP MODEL  
 LRH 850

