



# U.S. VACUUM PUMPS, LLC

## LRH-75/100/140

BARE SHAFT CONSTRUCTION W/ MECHANICAL SEAL



U.S. VACUUM LRH pumps are Two stage liquid ring vacuum pumps capable of producing a vacuum to 29" Hg . The pumps are available in various materials of construction ( FB = Iron/Bronze, FS = Iron/Stainless steel, SS = All stainless steel ).

Pumps are provided with threaded connections for service liquid, pump draining, vacuum relief valve and companion flanges. Optional items include inlet check valve, vacuum relief valve, flow control, solenoid valve, vacuum and temperature gauges.

Pumps can also come as completely packaged units using water or water as a seal fluid.

### TECHNICAL DATA

PUMP TYPE		LRH 75	LRH 100	LRH 140
Pumping Capacity (@ 25" Hg)	CFM	75	100	132
Speed	RPM	1750	1750	1750
Motor-Installed power	HP	7.5	7.5	10
Average service liquid flow	GPM	3.5	3.5	4
Noise level at 60 Torr	db(A)	68	68	68
Minimum suction pressure	Torr	25	25	25

### LRH 75 Dimensions

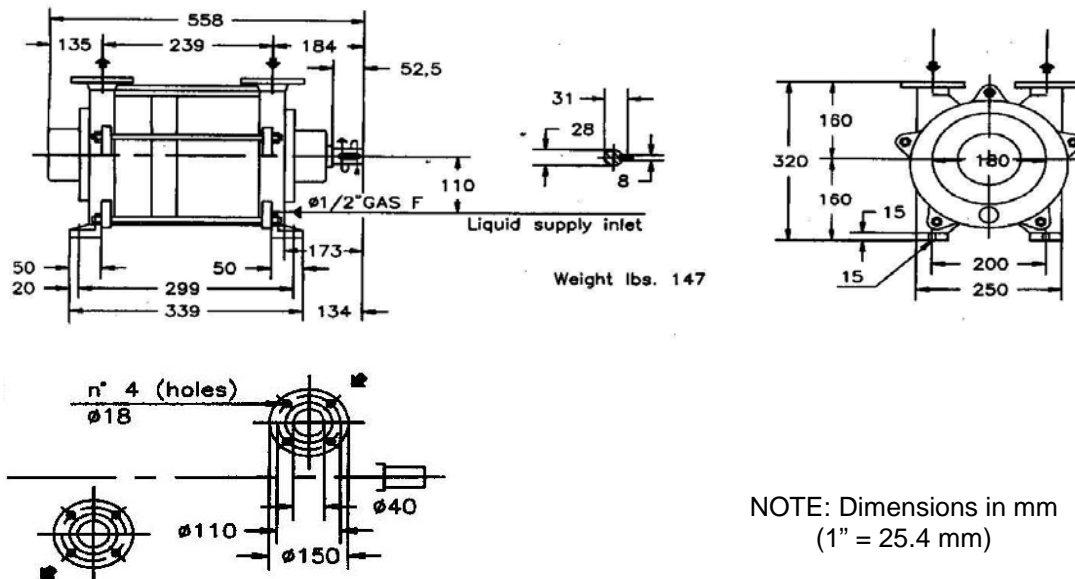

NOTE: Dimensions in mm  
(1" = 25.4 mm)

## LRH 100/140 Bare Shaft Dimensions

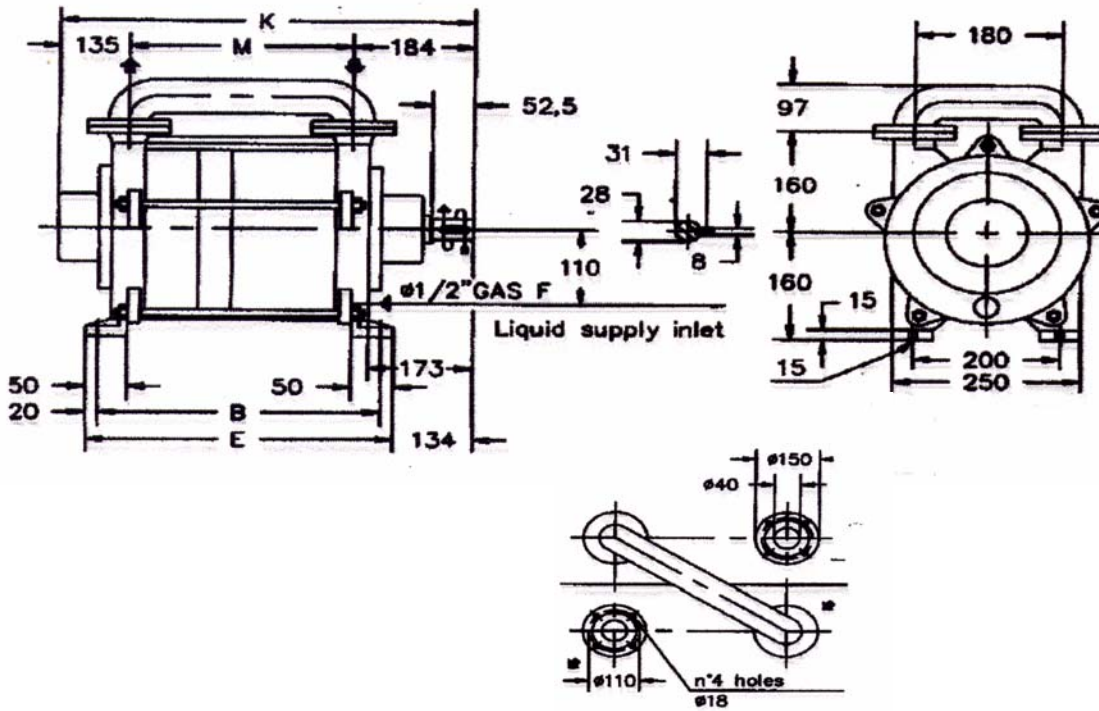

PUMP TYPE	B	E	M	K	Weight Lbs
LRH 100	329	369	269	588	174
LRH 140	399	439	339	658	192

NOTE: Dimensions in mm  
(1" = 25.4 mm)



# U.S. VACUUM

DATA BASED ON :  
DRY AIR AT 68 °F - 20 °C  
SATURATED AIR AT 68 °F - 20 °C  
SERVICE LIQUID WATER  
SERVICE LIQUID TEMPERATURE 59 °F - 15 °C  
DISCHARGE PRESSURE 1013 mbar

S.S. PUMPS  
CAPACITY : -10%

Tol.: 10%

PERFORMANCE DATA  
LIQUID RING VACUUM PUMP  
PUMP MODEL  
LRH 75

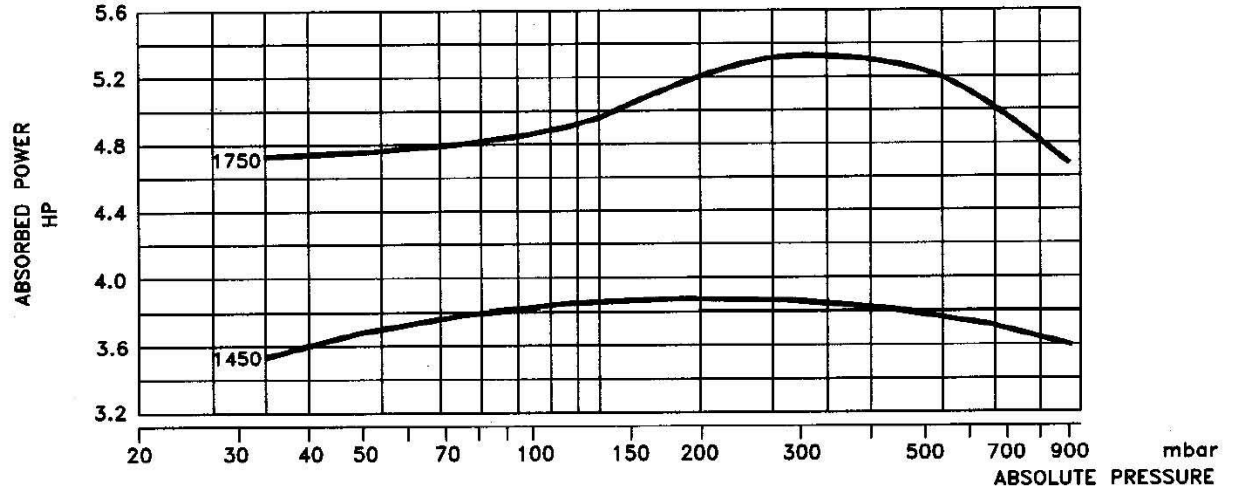
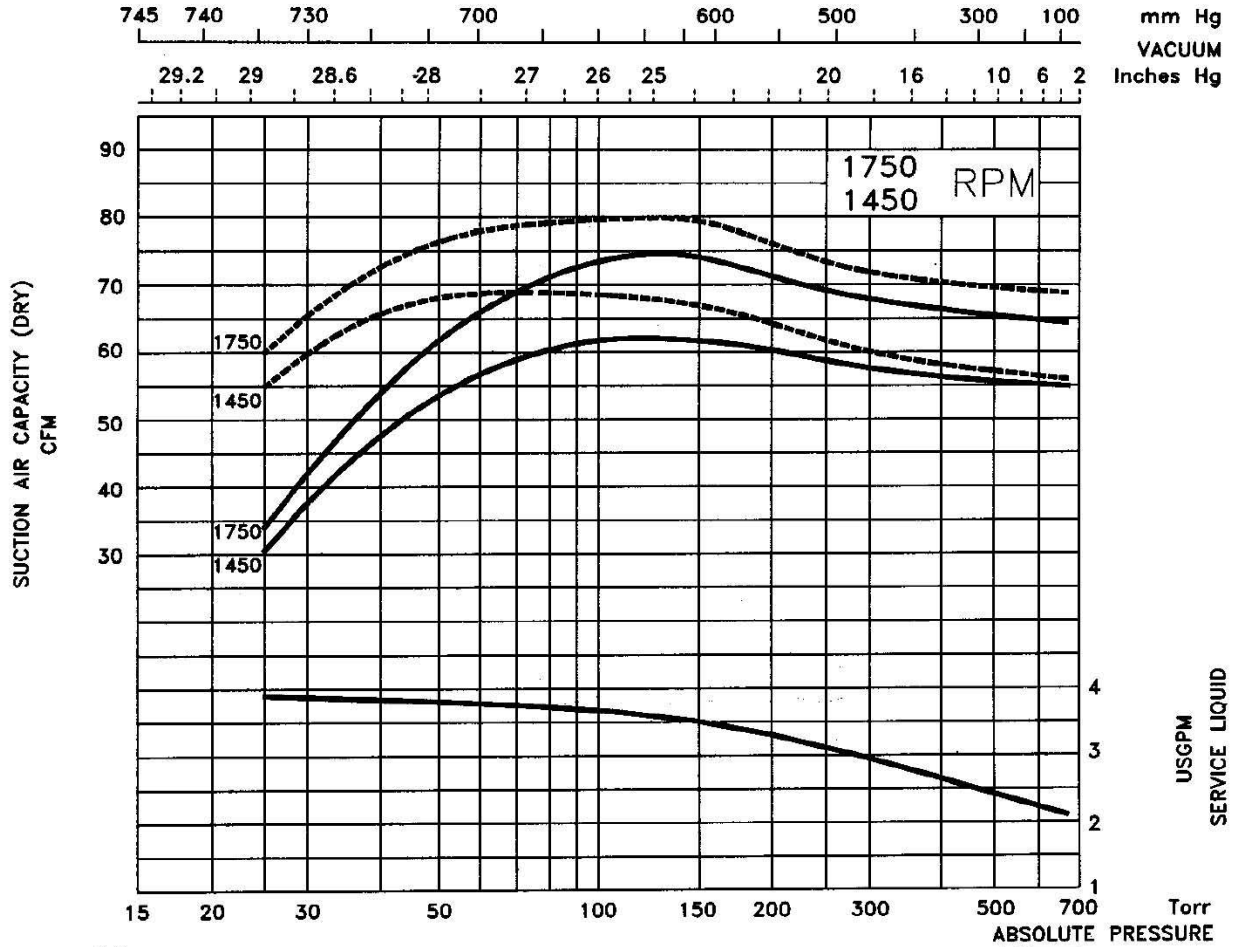



# U.S. VACUUM

DATA BASED ON :  
 DRY AIR AT 68 °F - 20 °C  
 SATURATED AIR AT 68 °F - 20 °C  
 SERVICE LIQUID WATER  
 SERVICE LIQUID TEMPERATURE 59 °F - 15 °C  
 DISCHARGE PRESSURE 1013 mbar

S.S. PUMPS  
 CAPACITY: -10%

Tol.: 10%

PERFORMANCE DATA  
 LIQUID RING VACUUM PUMP  
 PUMP MODEL  
 LRH 100

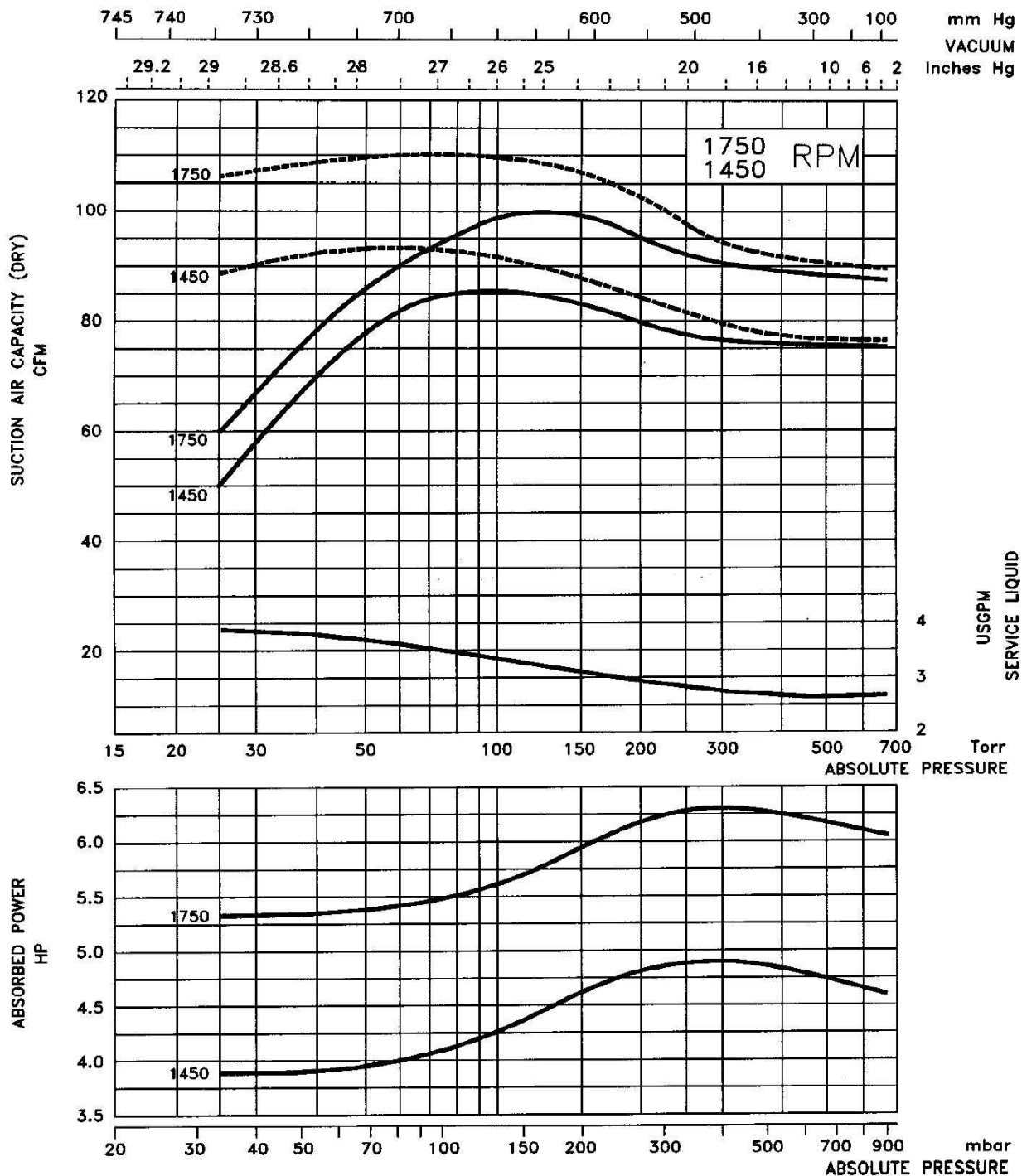



# U.S. VACUUM

DATA BASED ON :  
DRY AIR AT 68 °F - 20 °C  
SATURATED AIR AT 68 °F - 20 °C  
SERVICE LIQUID WATER  
SERVICE LIQUID TEMPERATURE 59 °F - 15 °C  
DISCHARGE PRESSURE 1013 mbar

S.S. PUMPS  
CAPACITY : -10%

Tol.: 10%

PERFORMANCE DATA  
LIQUID RING VACUUM PUMP  
PUMP MODEL  
LRH 140

