

COMPACT OSR SERIES

Oil Sealed Liquid Ring Systems 70-150 cfm

OSR Series Full Sealant Recovery System

- Low Cost
- Small footprint
- Air cooled
- Vacuum to 29" Hg
- Durable for long life
- No contaminating discharge

OSR systems are completely packaged turnkey closed-looped Oil sealed Liquid ring vacuum systems capable of producing a vacuum to 29" Hg. The systems are completely self contained and are AIR cooled.

The system consists of a close-coupled single stage liquid ring Vacuum pump, oil reservoir, high efficiency discharge separator filter, Air/Oil heat exchanger, inlet check valve, Inlet Particulate filter, vacuum gauges, and Start/Stop Switch (460v, 60hz).

Typical applications include: solvent & vapor recovery, CNC routers, soil remediation, sterilization, pharmaceuticals, food processing, vacuum forming, composite bagging



CLOSE-COUPLED VACUUM PUMP
FOR SPACE SAVINGS

Model	Nominal Capacity ACFM	Ultimate Vacuum "Hg	Noise Level dba	Motor Hp	Pump Speed RPM	Suction Connection (NPT)	Approximate Dimensions (in) L X W X H	Approximate Weight LBS
LRV-75C OSR	70	29" Hg	68	5	1750	1.5"	44 X 18 X 32	560
LRV-100C OSR	105	29" Hg	69	7.5	1750	1.5"	44 X 18 X 32	640
LRV-150C OSR	150	29" Hg	72	10	1750	1.5"	44 X 18 X 32	650



US Vacuum Pumps LLC * P.O. Box 909 * Canton, TX 75103
Phone: (888) 416-7366 * Fax: (877) 416-7599
WEB: www.usvacuumpumps.com

OSR SERIES

Oil Sealed Air-Cooled Vacuum Systems

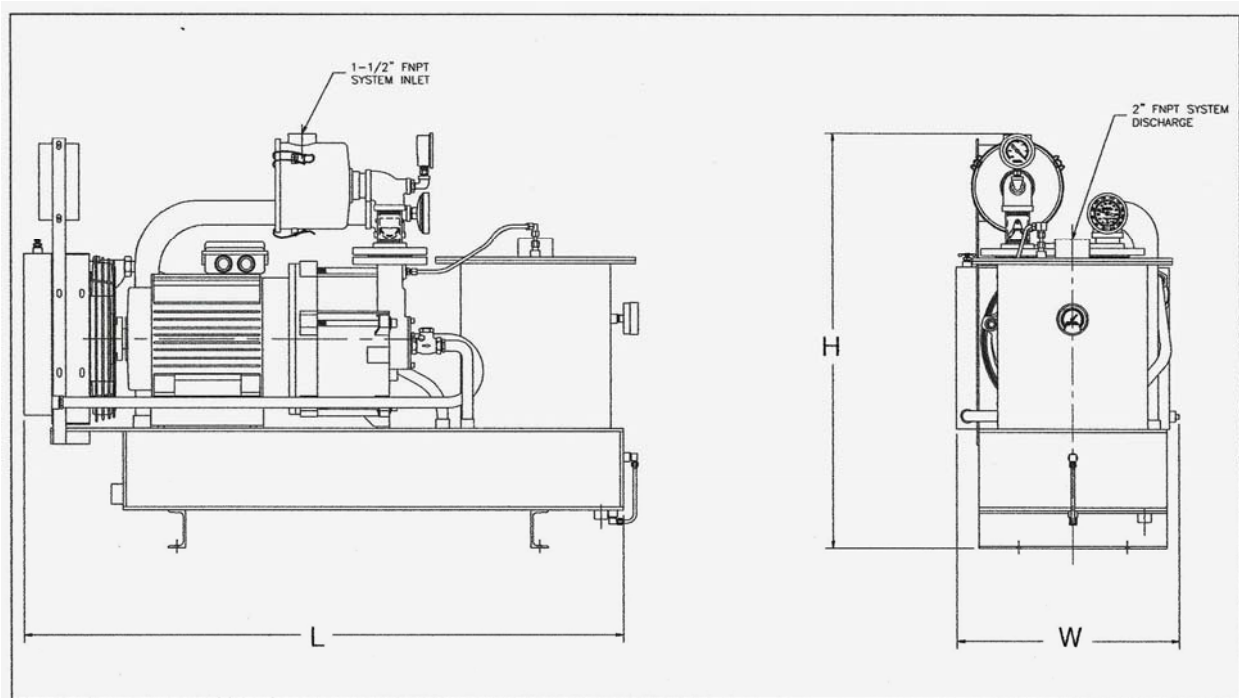

DIMENSIONS (in)			
MODEL	LENGTH	WIDTH	HEIGHT
LRV-75C OSR	44	18	32
LRV-100C OSR	44	18	32
LRV-150C OSR	44	18	32

WEIGHT
lbs
560
640
650

US VACUUM

US Vacuum Pumps LLC
 P.O. Box 909
 Canton, TX 75103
 Phone: (888) 416-7366
 Fax: (877) 416-7599
 WEB: www.usvacuumpumps.com

