

ROTARY PISTON Vacuum Pump

RP-150K™ & RP-300K™



US VACUUM RP series of Rotary Piston vacuum pumps are heavy duty INDUSTRIAL GRADE units capable of producing an ultimate vacuum of 0.010 mmHg (abs). The pump is designed for use in demanding industrial applications where high vacuum, high flow and heavy duty construction are required.

Triple-piston design provides for nearly vibration-free operation. Forced feed oil lubrication for operation at any pressures.

Common applications include vacuum furnace, resin infusion, transformer drying, altitude chambers, Degassing and pharmaceutical freeze drying.

FEATURES

- Industrial Duty design
- Vibration-free operation
- Forced feed lubrication
- Ultimate vacuum to 0.010 Torr
- Primary & Back-up lubrication system



PERFORMANCE

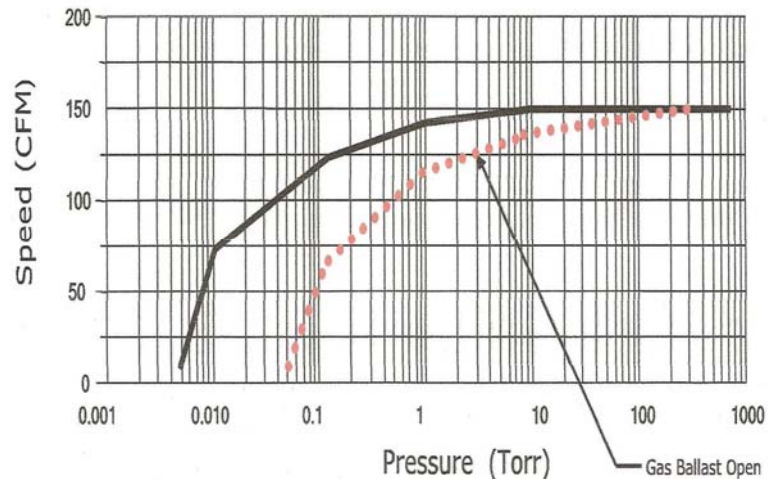

Pump Model		RP-150K	RP-300K
Displacement	CFM	150	300
Ultimate Vacuum	Torr	0.010 (10 Microns)	0.010 (10 Microns)
Motor	Hp	7.5	15
Pump Speed	RPM	1055	870
Oil Capacity	Gal	6	10
Inlet connection	Inches	3" ANSI	4" ANSI
Discharge connection	Inches	2" ANSI	3" ANSI
Noise Level	dBa	71	72
Cooling Water	gpm	1	1.5
Pump Weight	Lbs.	800	1525

DIMENSIONS

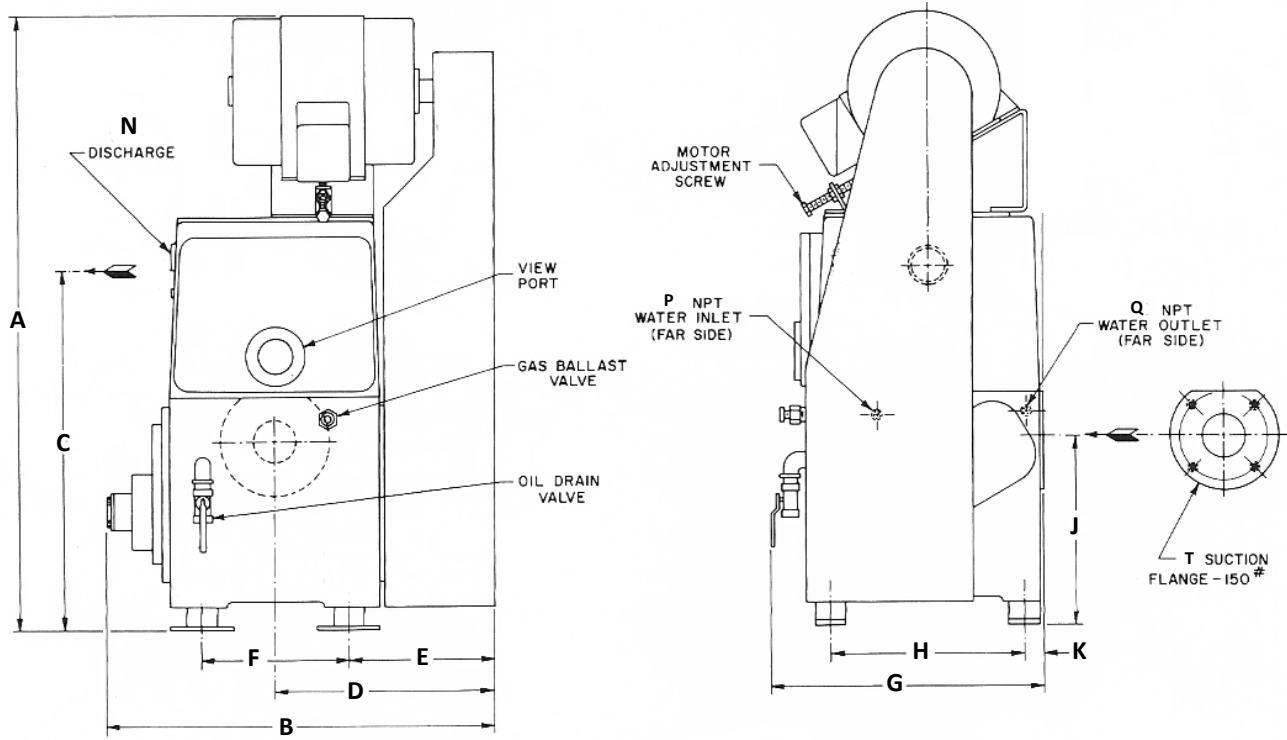

MODEL	A	B	C	D	E	F	G	H	J	K	N	P	Q	T
RP150K	1092	660	673	368	219	298	610	486	321	16	2	0.25	0.75	3
RP300K	1295	864	826	470	267	381	699	572	406	22	3	0.38	0.5	4

All dimensions in mm.
(25.4mm = 1")

US VACUUM

US Vacuum Pumps LLC
 P.O. Box 909
 Canton, TX 75103
 Phone: (888) 416-7366
 Fax: (877) 416-7599
 WEB: www.usvacuumpumps.com