



US VACUUM PUMPS

MODEL: RP-150H

COST EFFECTIVE 150 CFM ROTARY PISTON VACUUM PUMP

PERFORMANCE AND DURABILITY AT A REDUCED COST

INLET TRAPS, EXHAUST FILTERS, FLUIDS AVAILABLE

ALL SPARE PARTS IN STOCK

APPLICATIONS:

- ▶ Vacuum Heat Treating
- ▶ Vacuum Brazing
- ▶ Vacuum Coating
- ▶ Transformer Drying
- ▶ Degasification System
- ▶ Shelf Drying
- ▶ Vacuum Casting
- ▶ E-Beam Welding



Two Year Warranty

MODEL: RP-150H

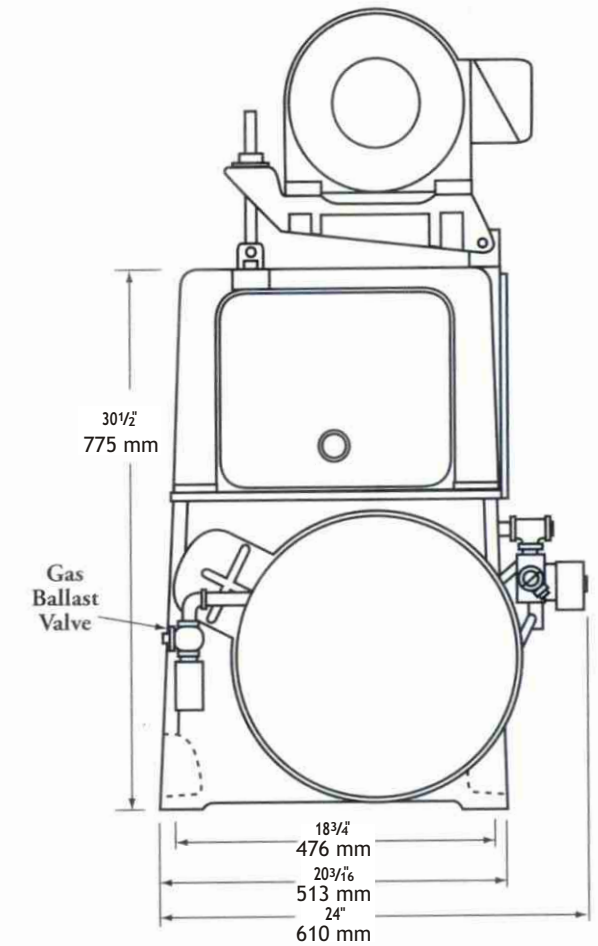
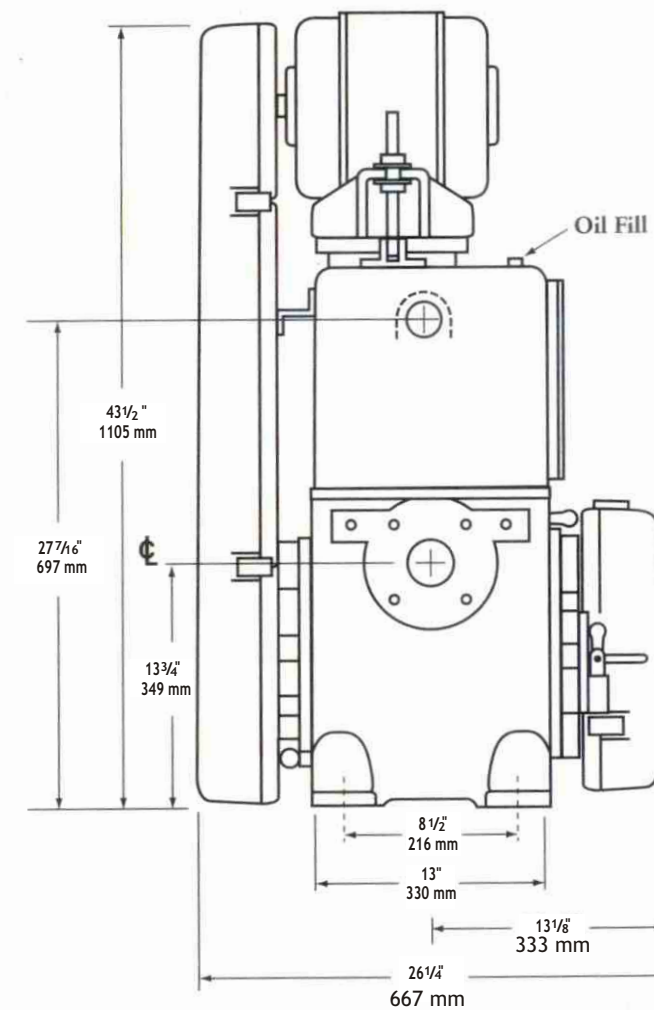

SPECIFICATIONS

Free Air Displacement 150 CFM (255M³/hr)
 VACUUM STAGES : One
 Ultimate Pressure: 0.01 TORR
 Motor Rating: 7.5 HP 208/230/460V
 Pump Speed: 500 RPM
 Oil Capacity: 4 Gals (15 liters)
 Weight: 950 lbs (430 Kg)
 Inlet (ASA Flange):..... 3"
 Outlet (Female NPT).....2"
 Max Cooling Water 65°F (18°C) 2GPM

C=DIRECT DRIVE; BP=BY-PASS
 NUMBER VALUE = CFM CAPACITY

CHICAGO OFFICE
 US VACUUM PUMPS LLC
 PH : 888-416-7366
 FX : 877-416-7599
 HELP@USVACUUMPUMPS.COM

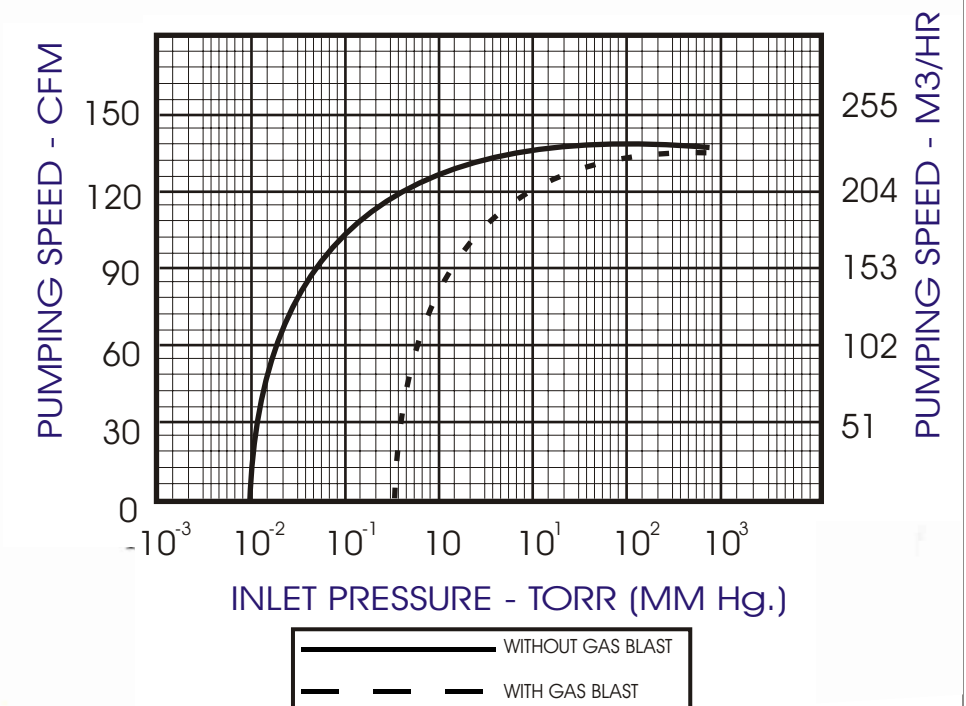

DALLAS OFFICE
 US VACUUM PUMPS LLC
 P.O. BOX 909 CANTON TX 75103
 PH : 888-416-7466
 FX : 877-416-7599
 HELP@USVACUUMPUMPS.COM