

ROTARY PISTON

Single Stage Vacuum Pumps



RP-35 & RP-50

US VACUUM RPC series of Rotary Piston compound vacuum pumps are heavy duty INDUSTRIAL GRADE units capable of producing an ultimate vacuum of 0.010 mmHg (abs).

These units have been EXCLUSIVELY DESIGNED for use in demanding industrial applications where high vacuum, high flow and heavy duty construction are required. The pumps come complete with motor, oil line solenoid valve, lubrication system, OSHA approved belt guard, vibration mounts and discharge oil mist filter.

Low pump rpm (400-550 rpm) and generous oil supply insures minimal wear and long term durability. Typical applications include transformer drying & degassing, refrigeration evacuation, vacuum ovens/chambers and general industrial use.

FEATURES

- Air Cooled
- Low Vibration
- Long lasting & durable
- Full pumping speed down to 1 Torr
- Absolute pressures to 0.010 Torr

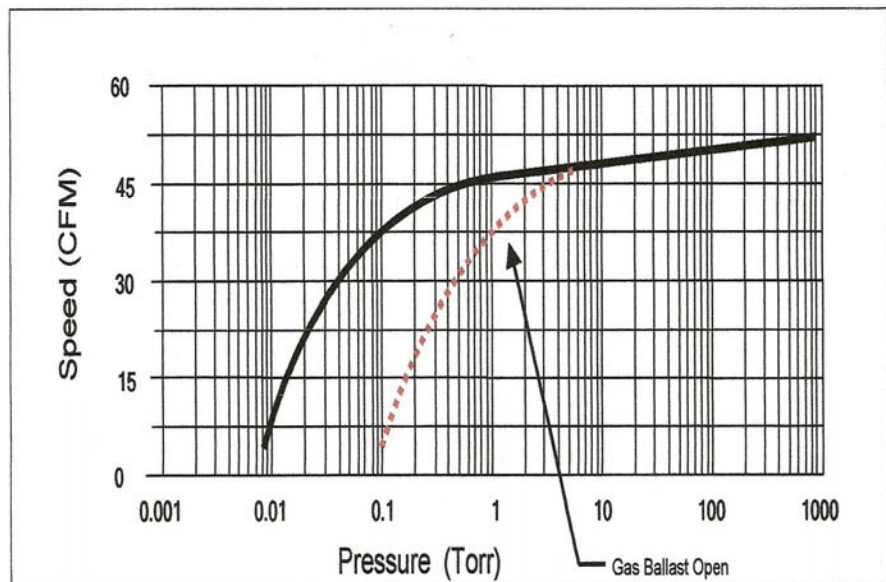

SPECIFICATIONS

Pump Model		RP-35	RP-50
Displacement	CFM	37	52
Ultimate Vacuum	Torr	0.010	0.010
Motor	Hp	1.5	2
Pump Speed	RPM	400	550
Oil Capacity	Gal	2	2
Inlet connection	in.	2"	2"
Exhaust connection	in.	1.5"	1.5"
Pump Weight	Lbs.	380	385

DIMENSIONS

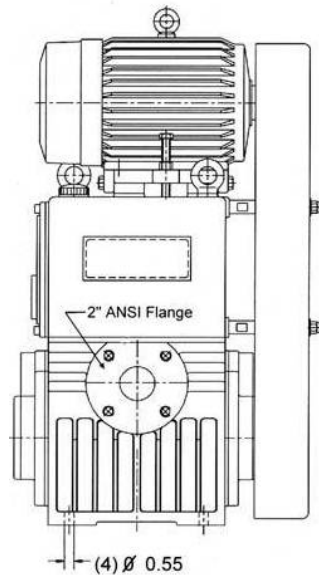
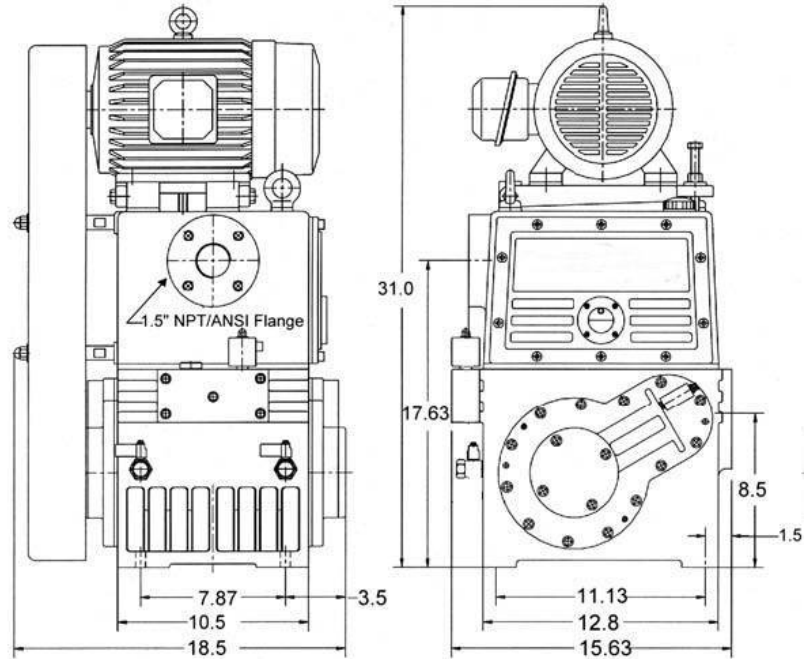

US VACUUM

US Vacuum Pumps LLC
P.O. Box 909
Canton, TX 75103
Phone: (888) 416-7366
Fax: (877) 416-7599
WEB: www.usvacuumpumps.com