

ROTARY PISTON

Vacuum Pump

For Hydrogen Seal Oil Purifiers



US VACUUM PUMPS LLC Model RP-50B-WS Rotary Piston vacuum pump is a heavy duty INDUSTRIAL GRADE unit capable of producing an ultimate vacuum of 10 microns abs (29.9"+ Hg).

The system has been EXCLUSIVELY DESIGNED for use in the power generating industry to distill off condensed water vapor out of generator turbine oil. The motor and solenoid valve are explosion-proof rated and an inline gear reducer is used to address safety concerns for the presence of hydrogen in the process gas stream.

Low pump rpm (350 rpm) and generous oil supply insures minimal wear to the pump from water diluted oil resulting in an exceptionally durable vacuum pumping system. One can easily expect 20+ years of use from this pumping system with only a minimal of routine maintenance required.

FEATURES

- Air Cooled
- No metal to metal contact
- Long lasting & durable
- Full pumping speed down to 1 Torr
- Absolute pressures to 0.050 Torr
- Over 40 years of proven reliability



SPECIFICATIONS

Pump Model	RP50B-WS	
Displacement	CFM	47
Ultimate Vacuum	Torr	0.010 (29.9"+Hg)
Motor	Hp	3
Pump Speed	RPM	350
Oil Capacity	Qt	
Inlet connection	in.	1.5" NPT
Exhaust connection	in.	2" NPT
Pump Weight	Lbs.	750

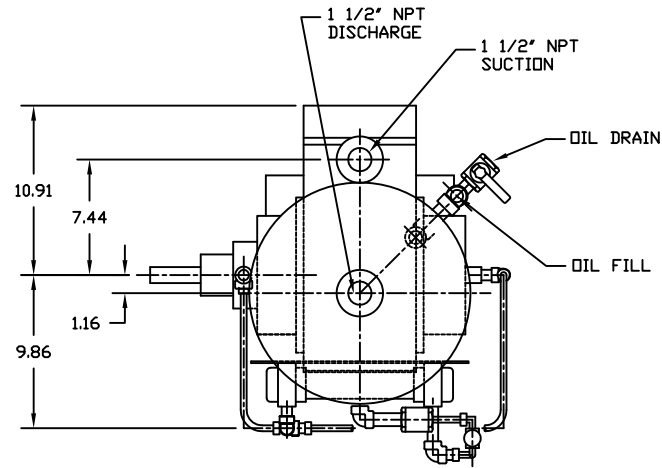

PLAN

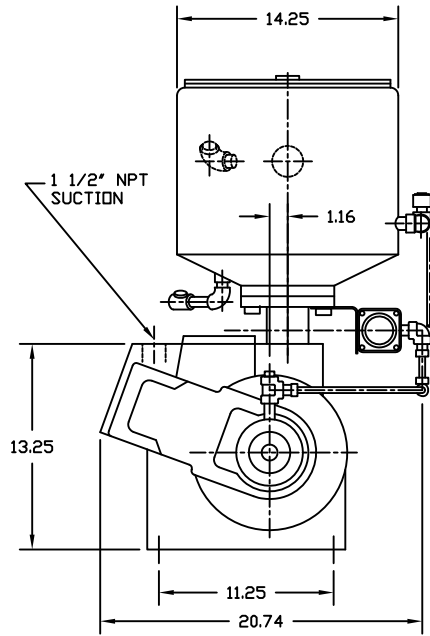

END VIEW

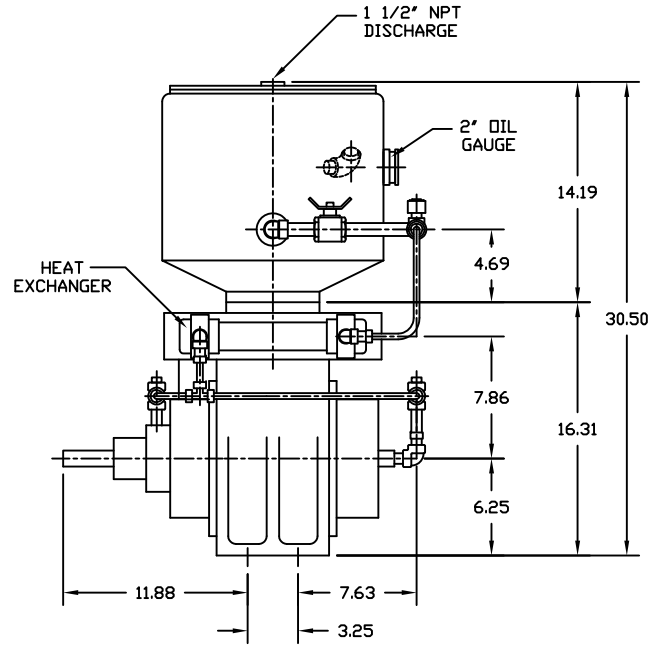

ELEVATION

- NOTES:
 1. ALL STANDARD UNIT PIPING SHALL BE SCH/40 ASTM A-53 TYPE F C/W 150# ASTM A-197 MALLEABLE IRON THREADED FITTINGS.
 2. DIMENSION TOLERANCE TO 1/4".

DIMENSIONS ARE IN INCHES [mm]
 WEIGHT IN LBS [kg]
 THIRD ANGLE PROJECTION

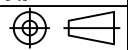

0	INITIAL RELEASE			JCM	PD	PD	21-APR-10
REV	DESCRIPTION			DWN	CK	APP	DATE
DWN	JCM	21-APR-10	<small>THIS DRAWING AND ALL INFORMATION SHOWN HEREON ARE THE EXCLUSIVE PROPERTY OF DMYXX VACUUM PUMPS AND ARE SUBMITTED ON A CONFIDENTIAL BASIS ONLY. THE RECIPIENT AGREES NOT TO REPRODUCE OR DISCLOSEURE OF THE DRAWING OR THE INFORMATION DRAWING, TO RETURN IT UPON REQUEST AND THAT NO SHOW HEREON WILL BE MADE TO THE THIRD PARTY WITHOUT PRIOR WRITTEN CONSENT OF DMYXX.</small>				
CK	PD	21-APR-10					
APP	PD	21-APR-10					
SCALE		1 1/2"=1'-0"					
VACUUM PUMP OUTLINE DRAWING				CERTIFIED DRAWING US VACUUM PUMPS, LLC P.O. BOX 909 CANTON, TEXAS 75103 PH: 888-416-7466 / FAX: 877-416-7599			
				DWG. NO. US-VAC-RP-50B		REV 0	