

# ROTARY PISTON 2-Stage Vacuum Pumps



## RPC-70 & RPC-95

**US VACUUM** RPC series of Rotary Piston compound vacuum pumps are heavy duty INDUSTRIAL GRADE units capable of producing an ultimate vacuum of 0.002 mmHg (abs).

These units have been EXCLUSIVELY DESIGNED for use in demanding industrial applications where high vacuum, high flow and heavy duty construction are required. The pumps come complete with motor, oil line solenoid valve, forced feed lubrication system, OSHA approved belt guard, vibration mounts and discharge oil mist filter.

Low pump rpm (500-700 rpm) and generous oil supply insures minimal wear and long term durability. Typical applications include transformer drying & degassing, refrigeration evacuation, electron beam welding, .

### FEATURES

- Air Cooled
- Forced feed lubrication
- Vibration-free operation
- Long lasting & durable
- Ultimate vacuum to 0.002 Torr

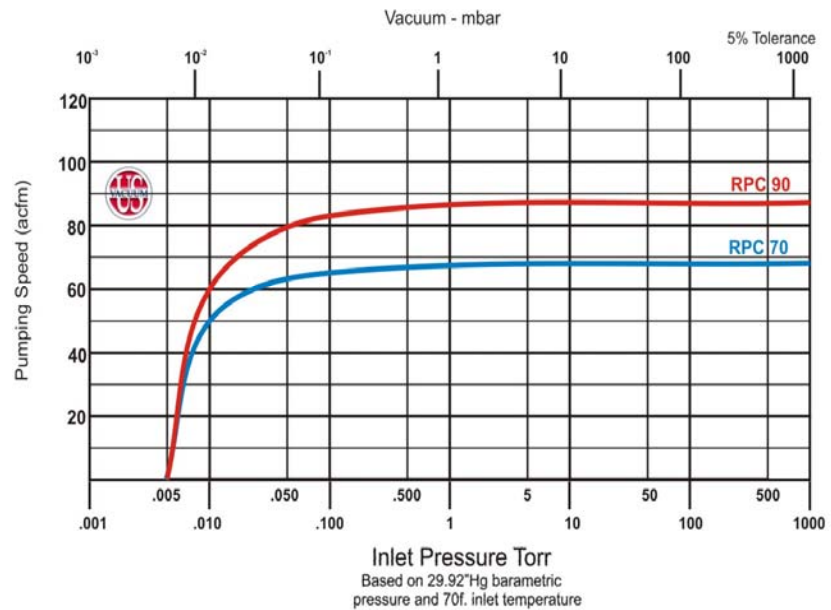

## SPECIFICATIONS

Pump Model		RPC-70	RPC-95
Displacement	CFM	71	95
Ultimate Vacuum	Torr	0.002	0.002
Motor	Hp	3	5
Pump Speed	RPM	500	700
Oil Capacity	Gal	3	3
Inlet connection	in.	2.5"	2.5"
Exhaust connection	in.	2"	2"
Pump Weight	Lbs.	745	750

# DIMENSIONS

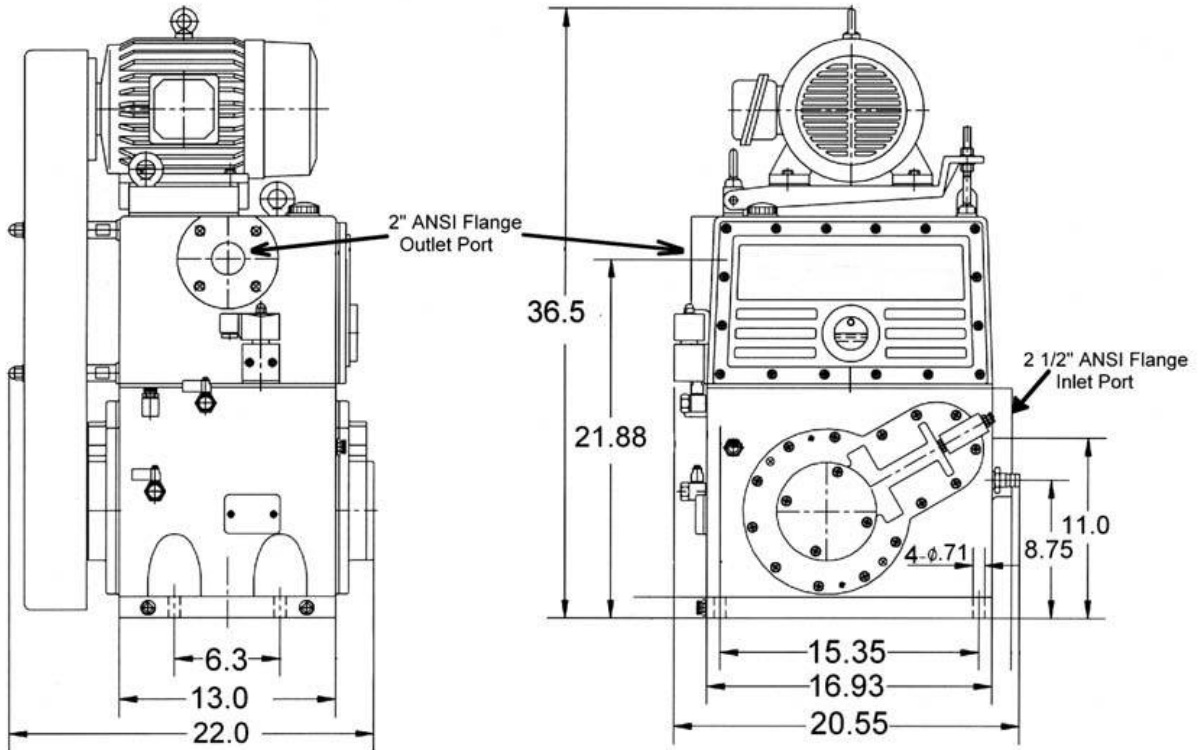

## US VACUUM

US Vacuum Pumps LLC  
P.O. Box 909  
Canton, TX 75103  
Phone: (888) 416-7366  
Fax: (877) 416-7599  
WEB: [www.usvacuumpumps.com](http://www.usvacuumpumps.com)