



US VACUUM PUMPS LLC

USV-15F ROTARY VANE SINGLE STAGE VACUUM PUMP



US VACUUM pump Model USV-15F is a Single stage, Air-cooled, Rotary vane vacuum pump capable of producing an ultimate vacuum to 2 mm Hg (29.8" Hg).

The pump is small and compact yet produces a very generous 15 cfm of inlet pumping capacity. Typical applications include vacuum drying, impregnation, food packaging, vacuum chucking and de-gassing.

Available standard with either 120v or 240v (1-ph) programmable Control panel w/ pressure transducer.

TECHNICAL DATA

PUMP TYPE		USV-15F
Pump Displacement	CFM	15
Ultimate Vacuum	Torr	2
Pump Speed	RPM	3500
Oil Capacity	ml	500
Inlet connection	Inch	1/2
Motor-Installed power	HP	1.5
Weight	LBS	42
Noise level	db(A)	72

Vacuum Tank system

- 15 cfm Vacuum pump
- 15 gallon tank
- 1.5hp Motor
- Inlet Filter
- Pressure Transducer
- Programmable Control Panel w/ Digital display and H-O-A switch
- Rubber mounts
- 120V & 230V (1-PH)



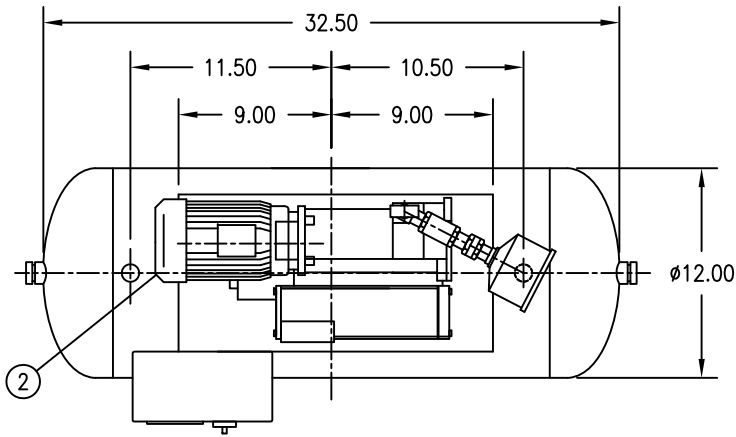

PLAN

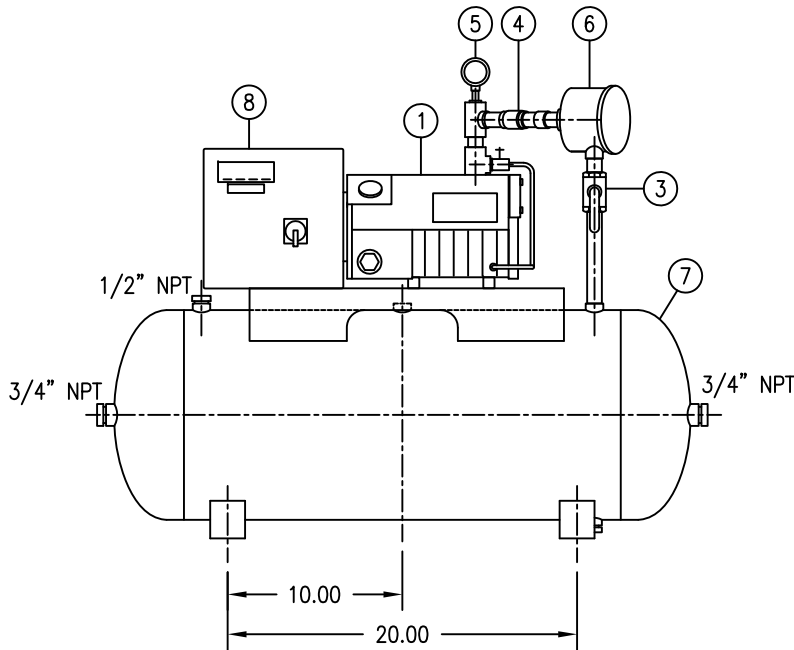

END VIEW

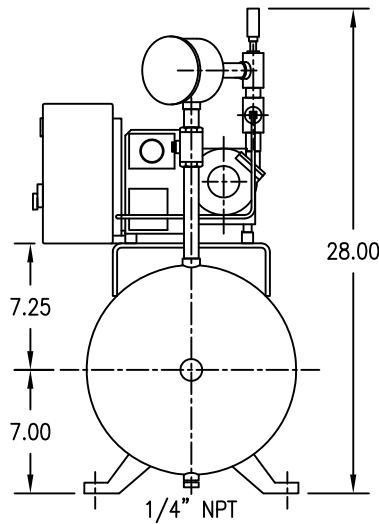

ELEVATION

BILL OF MATERIAL

NO.	QTY	DESCRIPTION	PART NUMBER
1	1	VACUUM PUMP MODEL CPS-15D	CPS15D11060
2	1	ELECTRIC MOTOR 1-1/4HP, 110V, 60HZ	EMCPS15B1.25
3	1	ISOLATION VALVE, BRASS 1/2"	IBVCPS15B.50
4	1	CHECK VALVE, ALUMINUM 1/2"	CVCP15B.50
5	1	VACUUM GAUGE, LIQUID FILLED, BRASS 1/4"	VGCP15B.25
6	1	PARTICULATE FILTER	VFISL824050
7	1	TANK, 15 GALLON	US302464
8	1	CONTROL PANEL, PROGRAMMABLE, DIGITAL DISPLAY	MSCPS15B110

NOTES:

1. ALL STANDARD UNIT PIPING SHALL BE SCH/40 ASTM A-53 TYPE F C/W 150# ASTM A-197 MALLEABLE IRON THREADED FITTINGS.
2. DIMENSION TOLERANCE TO 1/4".
3. CUSTOMER IS RESPONSIBLE FOR PROPER LIFTING EQUIPMENT FOR LIFTING SKID.
4. ANCHOR BOLTS ARE NOT FURNISHED WITH UNIT.

0	INITIAL RELEASE			JCM	PD	PD	20-JUL-11
REV	DESCRIPTION			DWN	CK	APP	DATE
DWN	JCM	20-JUL-11	THIS DRAWING AND ALL INFORMATION SHOWN HEREON ARE THE EXCLUSIVE PROPERTY OF US VACUUM PUMPS, LLC AND ARE SUBMITTED ON A CONFIDENTIAL BASIS ONLY. THE RECIPIENT AGREES NOT TO REPRODUCE THE DISCLOSURE OF THE DRAWING OR THE INFORMATION DRAWING, TO RETURN IT UPON REQUEST AND THAT NO SHOW HEREON WILL BE MADE TO THE THIRD PARTY WITHOUT PRIOR WRITTEN CONSENT OF US VACUUM PUMPS, LLC.	CERTIFIED DRAWING			
CK	PD	20-JUL-11		US VACUUM PUMPS, LLC			
APP	PD	20-JUL-11		P.O. BOX 909 CANTON, TEXAS 75103 PH: 888-416-7466 / FAX: 877-416-7599			
SCALE 3/4"=1'-0"				CPS-15D VACUUM PUMP SYSTEM w/ HORIZONTAL RECEIVER			
				DWG. NO.		REV	
				CPS15D-01		0	

DIMENSIONS ARE IN INCHES [mm]
WEIGHT IN LBS [kg]

THIRD ANGLE PROJECTION